

Industries We Serve...

Chemical Industries | R & D Industries | Pigment and Dyes Industries
Pharmaceutical Industries | Perfumery Industries | Lighting Industries
Fertilizer Industries | Precious Metal Industries



BHUMI SCIENTIFIC GLASS WORKS

C-20, Sardar Estate, Road No. 4, Ajwa Road, Vadodara - 390 019. Gujarat, India.
E : info@bhumiscientific.com, sales@bhumiscientific.com, marketing@bhumiscientific.com
M +91 76240 30006 / +91 88663 96912 / +91 9023698598

W : www.bhumiscientific.com



PRODUCT CATALOGUE



BOROSILICATE 3.3 GLASS

BHUMI SCIENTIFIC GLASS WORKS
www.bhumiscientific.com

ABOUT US

Bhumi Scientific is a leading name as the Scientific Glass Manufacturers & Suppliers of high grade Pipeline Component, industrial Valve, Vessels & Stirrers and other Component. Our offered range includes valve, jacketed Vessel, Heat Exchanger, Column Component, Structure Parts etc.

Bhumi Scientific & Products have established enviable reputation for its ability to Design, Manufacture & Distributor of high Quality products and under one roof and offering unmatched scientific glass performance and proven value.

We strive to serve customers with a dependable services and Quality Products at Very Competitive Price. Thanking our valuable customers who have supported us through the past and welcoming our new customers.

Why Us Bhumi Scientific products

Our diverse product lines include:

- * Excellent range of products
- * Excellent Quality Support
- * Competitive Price
- * Prompt Delivery



Quality Assurance:

Our quality assurance system is meant to increase customer confidence and a company's credibility, while also improving work processes and efficiency, and it enables a company to better compete with others.



Vision :

We make good quality of products, that's why we create space country around the world.



Mission :

Happy employee lead to happy customer, which lead to all growth.



Goal :

We focused on our goal and work hard on it daily.

LABORATORY GLASSWARE



PTFE PRODUCTS



CUSTOM GLASSWARE





PIPELINE COMPONENTS



HEAT EXCHANGERS



VALVES



COLUMN COMPONENTS



VESSELS



STANDARD UNITS



STIRRERS



**ROTARY FILM EVAPORATOR
2 TO 50 LITERS**

Borosilicate glass represents unmatched standardized glass for construction of plant and piping in the chemical, dyestuff, food pharmaceutical, petrochemical industries. Its steadily growing use is due to many advantages over conventional materials.

- Outstanding corrosion resistance
- Smooth pore free surface
- Transparency
- Catalytic inertness.
- No effect on taste and odour
- Physiological inertness.

Borosilicate glass is chosen for its unique chemical and physical properties. Borosilicate glass can be considered as being composed of Oxides, Silica (SiO₂), Magnesia (MgO) and Lead oxide (PbO) are the principle modifiers/fluxes.

The chemical and physical properties of any glass depends on a varying degree on chemical composition of glass.

CHEMICAL COMPOSITION

The composition of borosilicate glass used for chemical plants has following approximate composition.

SiO ₂ - 80.6%	B ₂ O ₂ - 12.5%
Na ₂ O - 4.2%	Al ₂ O ₃ - 2.2%

RESISTANCE TO CHEMICAL

Borosilicate glass is inert to almost all materials except Hydroflouric acid (HF) Phosphoric acid(H₃PO₄) and hot strong caustic solutions. Of these, Hydroflouric acid has the most serious effect, even when it is present in PPM (parts per million) in solutions. Where as phosphoric acid and caustic solutions cause no problems when cold but at elevated temperature corrosion occurs. In case of caustic solutions, upto 30% concentration can be handled safely at ambient temperature.

Under actual operating conditions, the effect of turbulence, and traces of other chemicals in the solution may increase or decrease the rate of attack. So it is not possible to give exact figures for corrosion by caustic solutions.

THERMAL PROPERTIES

Linear coefficient of thermal expansion

The coefficient of thermal expansion of borosilicate glass over the temperature 0-300°C is 3.3 x 10⁻⁶/°C. This is very low when compared with other glasses and metals. That is why, borosilicate glass is often called low expansion borosilicate glass.

Specific heat

Specific heat between 25°C and 300°C is average to be 0.233Kcal/Kg, °C

Thermal Conductivity

Thermal conductivity is 1.0 Kcal/hr,m°C. Over the permissible operating temperature range.

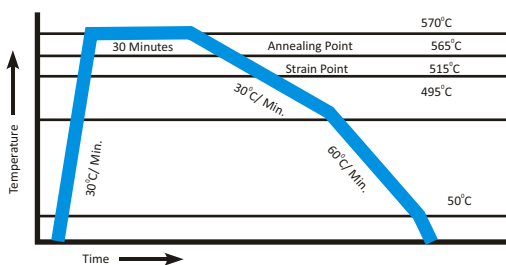

ANNEALING

Annealing of glass is the process where the glass is heated and kept for a defined period of time to relieve internal stresses. Careful cooling under controlled conditions is essential to ensure that no stresses are reintroduced by chilling/cooling.

RESHAPEING

In the below given table, it shows characteristic temperature at a determined viscosity, essential for glass reshape.

Lower cooling temperature	10 ²¹ poise	515°C
Upper cooling temperature	10 ¹³ poise	565°C
Softening point	10 ⁷ poise	795°C
Reshapeing point	10 ⁴ poise	120°C

MECHANICAL PROPERTIES

The lack of ductility of glass prevents the equalization of stresses at local irregularities or flaws and the breakage strength varies considerably about a mean value. This latter is found to occur at a tensile strength of about 700kg/cm² In order to allow for the spread of breaking stress, a large factor of safety is applied when determining the wall thickness requirement to allow operation up to values given in the table of working pressure.

OPTICAL PROPERTIES

Borosilicate glass show no appreciable absorption in the visible region of spectrum and therefore appears clear and colourless.

In photo chemical processes, the transparency of ultra violet is of particular importance. It follows from the transmittance of material in uv region that photo chemical reactions such as Chlorination & Sulpho Chlorination can be performed in it.

PERMISSIBLE OPERATING CONDITIONS

Working Pressure For Glass Pipelines & Vessels

The permissible internal operation pressure depends upon the nominal diameter of the glass components and on working temperature.

In case of unit with various combination like vessels, filters, heat exchangers, the overall permissible internal gauge pressure is always governed by the component with the lowest permissible operating gauge pressure all components are suitable for full vacuum

Bar is a measure of absolute pressure. The figure given for maximum recommended working pressure represents pressure above atmospheric.

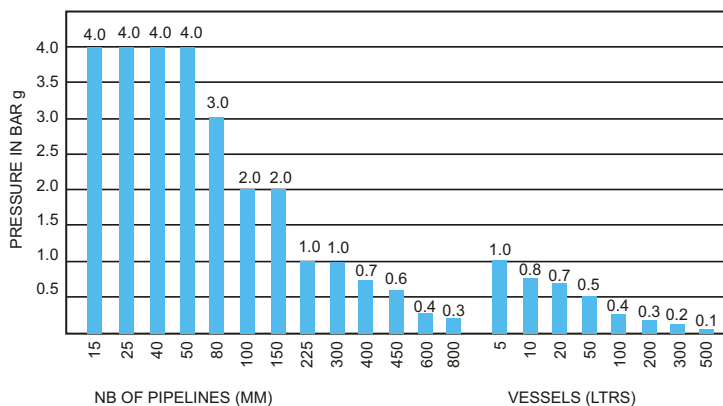

Working Temperature

Borosilicate glass retains its mechanical strength and will deform only at temperature which approach its strain point. The practical upper limit for operating temperature is much lower and is controlled by the temperature differentials in the glass which depends on the relative temperature of the contents of the equipment and the external surroundings. Provided borosilicate glass is not subject to rapid change in temperature, creating undue thermal shock, it can be operated safely at temperatures upto 250°C

It must be realised that in complete plants, composed not only of borosilicate glass, but also include other materials such as PTFE. The recommended max. operating temperature is 200°C. Operating temperatures may have to be modified so as to compensate for the effects of other factors such as pressure, thermal cycling, rapid heating & cooling etc.

The degree of thermal shock (usually defined as sudden chilling or heating) which it can withstand depends on many factors such as stresses due to operating conditions, stresses imposed in supporting the equipment, the wall thickness of the glass. It is therefore undesirable to give sudden temperature changes. But up to 120°C can be accommodated.

As sub zero temperature, the tensile strength of borosilicate glass tends to increase and equipment can be used safely at temperatures as low as -50°C for XTRONG and components.

COMPOSITE MATERIALS

The last two decades have seen the new or further developments of particularly corrosion resistant plant construction materials. Typical examples of these are PTFE, tantalum, titanium, graphite and of course, Borosilicate 3.3 Glass.

The combination of different corrosion resistant materials with the utilization of the specific advantages of each permits both safe and economic construction.

Borosilicate glass/PTFE

Borosilicate Glass with PTFE is of particularly decisive importance for construction of glass installation For example. in Seals, Bellows, Stirrers, Pumps, Heat Exchangers, Column Inserts etc.

PTFE is used with Glass because of its excellent mechanical & thermal properties. They have near universal fluid compatibility. Wear life when compared with others is very low. Particularly PTFE is maintenance free and have cryogenic stability with non wetting property.

Service temperature of PTFE is considered as - 50°C to + 200°C

ELECTRICAL CHARACTERISTICS

Glass being a poor electrical conductor, surface, conductivity is insignificant and varies with the quantity of water absorbed on glass surface. The specific conductivity is 10¹⁰ohm/cm at temperature of 200°C.

The dielectric coefficient varies with current frequency.

PIPELINE COMPONENTS



Borosilicate glass 3.3 pipeline offer many advantages for its use in chemical, pharmaceutical industries together with precious metal refining, dye works & electroplating because of its following characteristics.

1. Inert to almost all chemicals, hence no risk of contamination and no unwanted flavours or colours are imparted into product.
2. Transparency allows visual monitoring of the process, flow patterns, colour changes etc.
3. Almost universal resistance to corrosion. Along service life is guaranteed.
4. Smooth surface permits easy cleaning and prevents fouling.

All the components are suitable for operation under full vacuum conditions.

Pipeline Components are available from DN 15 to DN 600.
DN 800 pipeline parts are available on request.

PIPE SECTIONS

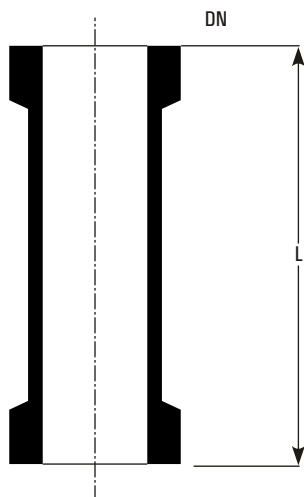

DN	15	25	40	50
L	Cat.Ref.	Cat.Ref.	Cat.Ref.	Cat.Ref.
100	PS0.7/100	PS1/100	PS1.5/100	PS2/100
150	PS0.7/150	PS1/150	PS1.5/150	PS2/150
200	PS0.7/200	PS1/200	PS1.5/200	PS2/200
250	PS0.7/250	PS1/250	PS1.5/250	PS2/250
300	PS0.7/300	PS1/300	PS1.5/300	PS2/300
400	PS0.7/400	PS1/400	PS1.5/400	PS2/400
500	PS0.7/500	PS1/500	PS1.5/500	PS2/500
600	PS0.7/600	PS1/600	PS1.5/600	PS2/600
750	PS0.7/750	PS1/750	PS1.5/750	PS2/750
900	PS0.7/900	PS1/900	PS1.5/900	PS2/900
1000	PS0.7/1000	PS1/1000	PS1.5/1000	PS2/1000

DN	80	100	150
L	Cat.Ref.	Cat.Ref.	Cat.Ref.
150	PS3/150	PS4/150	PS6/150
200	PS3/200	PS4/200	PS6/200
250	PS3/250	PS4/250	PS6/250
300	PS3/300	PS4/300	PS6/300
400	PS3/400	PS4/400	PS6/400
500	PS3/500	PS4/500	PS6/500
600	PS3/600	PS4/600	PS6/600
750	PS3/750	PS4/750	PS6/750
900	PS3/900	PS4/900	PS6/900
1000	PS3/1000	PS4/1000	PS6/1000

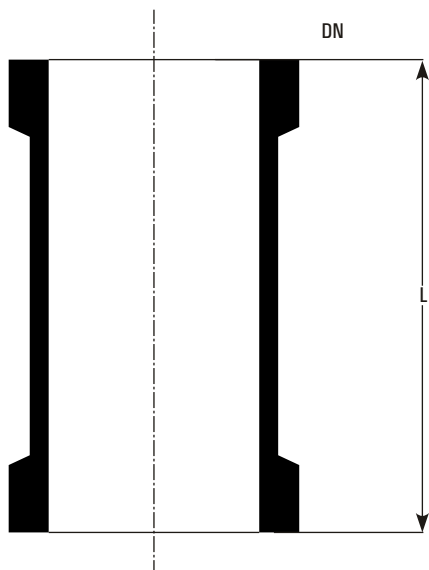

DN	225	300
L	Cat.Ref.	Cat.Ref.
300	PS9/300	PS12/300
400	PS9/400	PS12/400
500	PS9/500	PS12/500
600	PS9/600	PS12/600
750	PS9/750	PS12/750
900	PS9/900	PS12/900
1000	PS9/1000	PS12/1000
1200	PS9/1200	PS12/1200
1500	PS9/1500	PS12/1500

DN	400	450
L	Cat.Ref.	Cat.Ref.
300	PS16/300	PS18/300
500	PS16/500	PS18/500
750	PS16/750	PS18/750
1000	PS16/1000	PS18/1000
1200	PS16/1200	PS18/1200
1500	PS16/1500	PS18/1500

SPACERS

Spacers are used to make-up small increments in length.

DN	Type	15	25	40	50
L		Cat.Ref.	Cat.Ref.	Cat.Ref.	Cat.Ref.
5	A	SS0.7/5	SS1/5	SS1.5/5	SS2/5
15	A	SS0.7/15	SS1/15	SS1.5/15	SS2/15
25	A	SS0.7/25	SS1/25	SS1.5/25	SS2/25
50	B	SS0.7/50	SS1/50	SS1.5/50	SS2/50

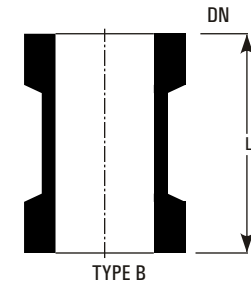
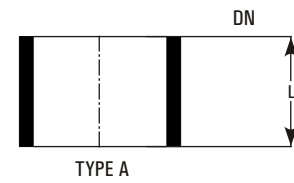

PTFE SPACERS

DN	25	40	50
L	Cat.Ref.	Cat.Ref.	Cat.Ref.
5	SST1/5	SST1.5/5	SST2/5
10	SST1/10	SST1.5/10	SST2/10
15	SST1/15	SST1.5/15	SST2/15
20	SST1/20	SST1.5/20	SST2/20

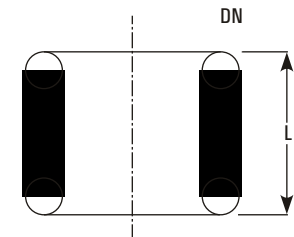

EQUAL TEES

Cat.Ref.	DN	L
PT0.7	15	50
PT1	25	100
PT1.5	40	150
PT2	50	150
PT3	80	200
PT4	100	250
PT6	150	250
PT9	225	375
PT12	300	450

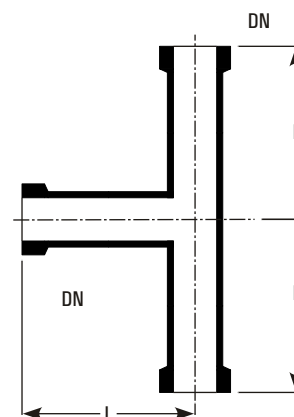

UNEQUAL TEES

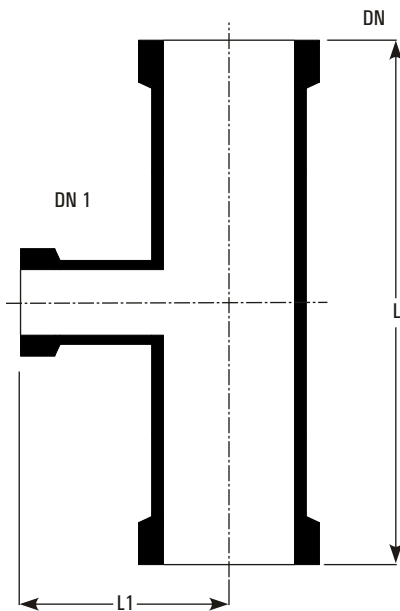

Cat.Ref.	DN	DN1	L	L1
PTU1/0.7	25	15	150	75
PTU1.5/1	40	25	200	75
PTU2/1	50	25	200	80
PTU2/1.5	50	40	200	100
PTU3/1	80	25	250	100
PTU3/1.5	80	40	250	100
PTU3/2	80	50	250	115
PTU4/1	100	25	250	110
PTU4/1.5	100	40	250	125
PTU4/2	100	50	250	125
PTU4/3	100	80	300	150
PTU6/1	150	25	250	150
PTU6/1.5	150	40	250	150
PTU6/2	150	50	250	150
PTU6/3	150	80	300	175
PTU6/4	150	100	300	200
PTU9/1	225	25	300	185
PTU9/1.5	225	40	300	185
PTU9/2	225	50	300	185
PTU9/3	225	80	300	210
PTU9/4	225	100	450	250
PTU9/6	225	150	450	275
PTU12/1	300	25	400	230
PTU12/1.5	300	40	400	230
PTU12/2	300	50	400	230
PTU12/3	300	80	400	275
PTU12/4	300	100	400	275
PTU12/6	300	150	450	300
PTU12/9	300	225	600	300
PTU16/1.5	400	40	400	275
PTU16/2	400	50	400	275
PTU16/3	400	80	400	300
PTU16/4	400	100	400	300
PTU16/6	400	150	500	350
PTU16/9	400	225	800	450
PTU16/12	400	300	800	450
PTU18/1.5	450	40	400	300
PTU18/2	450	50	400	300
PTU18/3	450	80	400	320
PTU18/4	450	100	400	320
PTU18/6	450	150	600	380
PTU18/9	450	225	800	400
PTU18/12	450	300	800	400
PTU24/4	600	100	600	450
PTU24/6	600	150	600	450
PTU24/9	600	225	800	525
PTU24/12	600	300	800	525

REDUCERS

Cat.Ref.	DN	DN1	L
PR1/0.7	25	15	100
PR1.5/1	40	25	100
PR2/1	50	25	100
PR2/1.5	50	40	100
PR3/1	80	25	125
PR3/1.5	80	40	125
PR3/2	80	50	125
PR4/1	100	25	150
PR4/1.5	100	40	150
PR4/2	100	50	150
PR4/3	100	80	150
PR6/1	150	25	200
PR6/1.5	150	40	200
PR6/2	150	50	200
PR6/3	150	80	200
PR6/4	150	100	200
PR9/1	225	25	250
PR9/1.5	225	40	250
PR9/2	225	50	250
PR9/3	225	80	250
PR9/4	225	100	250
PR9/6	225	150	250
PR12/1	300	25	300
PR12/1.5	300	40	300
PR12/2	300	50	300
PR12/3	300	80	300
PR12/4	300	100	300
PR12/6	300	150	300
PR12/9	300	225	300
PR16/1.5	400	40	350
PR16/2	400	50	350
PR16/3	400	80	350
PR16/4	400	100	350
PR16/6	400	150	350
PR16/9	400	225	350
PR16/12	400	300	350
PR18/1.5	450	40	375
PR18/2	450	50	375
PR18/3	450	80	375
PR18/4	450	100	375
PR18/6	450	150	375
PR18/9	450	225	375
PR18/12	450	300	375

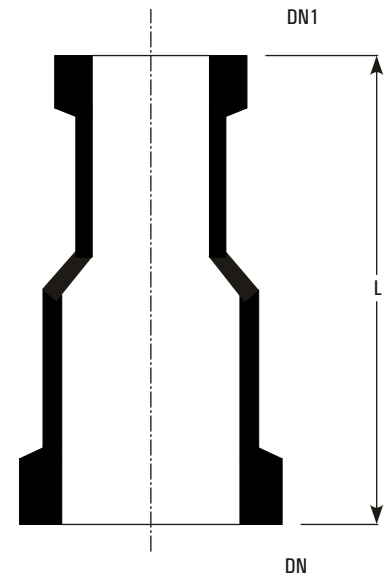

BENDS 90°

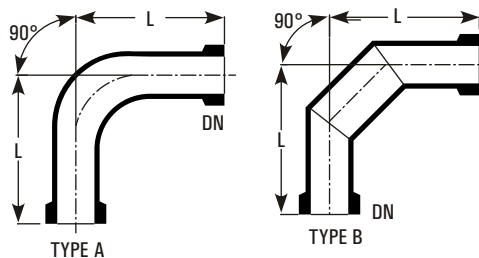

Cat.Ref.	DN	L	TYPE
PB0.7/90	15	50	A
PB1/90	25	100	A
PB1.5/90	40	150	A
PB2/90	50	150	A
PB3/90	80	200	B
PB4/90	100	250	B
PB6/90	150	250	B
PB9/90	225	375	B
PB12/90	300	450	B

Bends in 80 and 100 degree are also available with same dimensions.
Bends DN 400/DN 450/DN 600 on request basis.

BENDS 45°

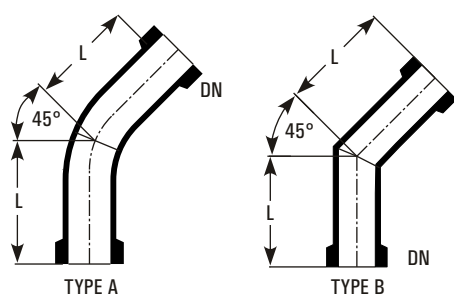

Cat.Ref.	DN	L	TYPE
PB0.7/45	15	50	A
PB1/45	25	75	A
PB1.5/45	40	100	A
PB2/45	50	100	A
PB3/45	80	125	B
PB4/45	100	175	B
PB6/45	150	250	B
PB9/45	225	375	B

Bends in 10 and 30 degree are also available with same dimensions.

U BENDS

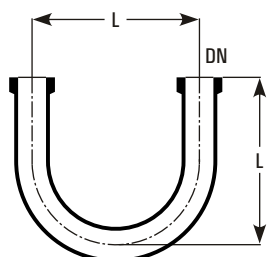

Cat.Ref.	DN	L
PU0.7	15	75
PU1	25	150
PU1.5	40	175
PU2	50	175
PU3	80	225

Y BENDS

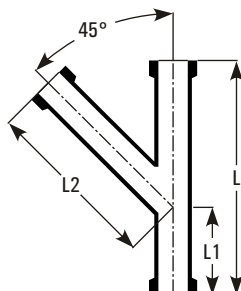

Cat.Ref.	DN	L	L1	L2
PY0.7	15	125	50	80
PY1	25	200	75	150
PY1.5	40	250	100	175
PY2	50	300	125	200
PY3	80	350	150	250
PY4	100	450	150	350

BENDS 90° WITH THERMOMETER BRANCH

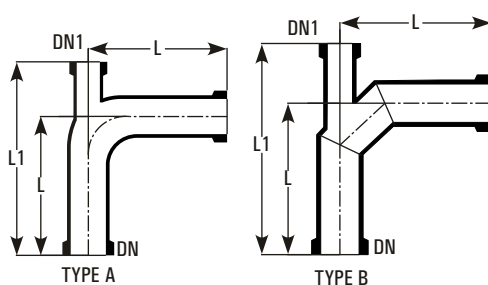

Cat.Ref.	DN	DN1	L	L1	TYPE
PBT1.5	40	25	150	225	A
PBT2	50	25	150	225	A
PBT3	80	25	200	275	B
PBT4	100	25	250	325	B
PBT6	150	25	250	325	B
PBT9	225	25	375	490	B
PBT12	300	25	450	560	B

U BENDS WITH BOTTOM OUTLET

Cat.Ref.	DN	DN1	L	L1
PUO0.7	15	15	150	100
PUO1/0.7	25	15	250	150
PUO1	25	25	250	150
PUO1.5	40	40	275	175
PUO1.5/1	40	25	275	175
PUO2	50	50	275	175
PUO2/1	50	25	275	175
PUO3/1	80	25	350	225

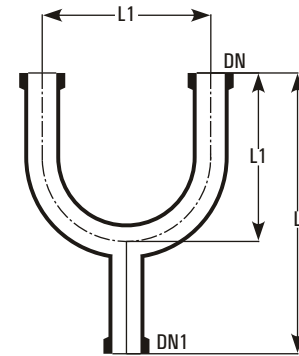

UNEQUAL CROSSES

Cat.Ref.	DN	DN1	DN2	L	L1	L2
PXU2/1/1	50	25	25	200	80	80
PXU2/1.5/1	50	40	25	200	100	80
PXU3/1/1	80	25	25	250	100	100
PXU3/1.5/1	80	40	25	250	100	100
PXU3/2/1	80	50	25	250	115	100
PXU4/1/1	100	25	25	250	110	110
PXU4/1.5/1	100	40	25	250	125	110
PXU4/2/1	100	50	25	250	125	110
PTU4/3/1	100	80	25	300	150	150
PXU6/1.5/1	150	40	25	250	150	150
PXU6/2/1	150	50	25	250	150	150
PXU6/3/2	150	80	50	300	175	150
PXU6/4/2	150	100	50	300	200	150
PXU9/1.5/1.5	225	40	40	300	185	185
PXU9/2/1.5	225	50	40	300	185	185
PXU9/3/1.5	225	80	40	300	210	185
PXU9/4/2	225	100	50	450	250	185
PXU9/6/3	225	150	80	450	275	210
PXU12/2/1.5	300	50	40	400	230	230
PXU12/3/1.5	300	80	40	400	275	230
PXU12/4/1.5	300	100	40	400	275	230
PXU12/6/2	300	150	50	450	300	230
PXU12/9/3	300	225	80	600	300	275
PXU16/1.5/1.5	400	40	40	400	275	275
PXU16/3/1.5	400	80	40	400	300	275
PXU16/4/1.5	400	100	40	400	300	275
PXU16/6/3	400	150	80	500	350	300
PXU16/9/4	400	225	100	800	450	300
PXU18/1.5/1.5	450	40	40	400	300	300
PXU18/3/1.5	450	80	40	400	320	300
PXU18/4/1.5	450	100	40	400	320	300
PXU18/6/3	450	150	80	600	380	320
PXU18/9/4	450	225	100	800	400	320

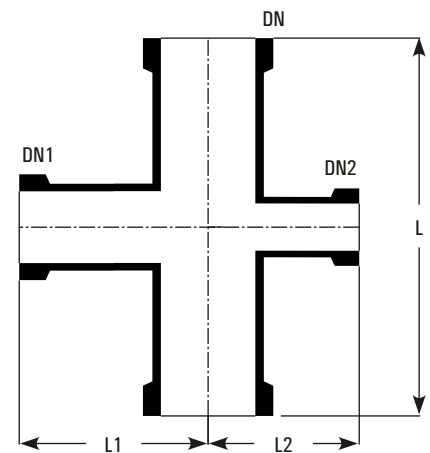

CROSSES

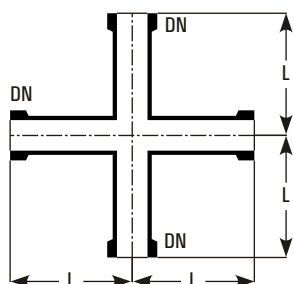

Cat.Ref.	DN	L
PX0.7	15	50
PX1	25	100
PX1.5	40	150
PX2	50	150
PX3	80	200
PX4	100	250

CLOSURES

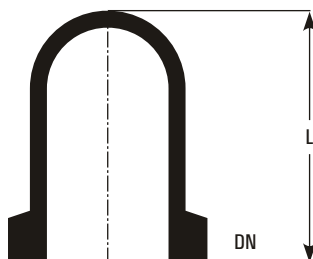

Cat.Ref.	DN	L
PBE0.7	15	40
PBE1	25	50
PBE1.5	40	75
PBE2	50	75
PBE3	80	100
PBE4	100	125
PBE6	150	125
PBE9	225	150
PBE12	300	150

JACKETED PIPE SECTIONS

Glass Jackets

For heating of pipe and for controlling the temperature throughout the column, the jacketed pipe sections are provided. Glass jacket is sealed to the pipe section using Viton 'O' ring and other sealing compositions. The seal prevents impermissibly high stresses between two tubes and allows the movement which comes due to thermal expansion. Maximum operating pressure in the jacket :

DN 80 - DN 150 1.0 bar
 DN 225 - DN 300 0.5 bar

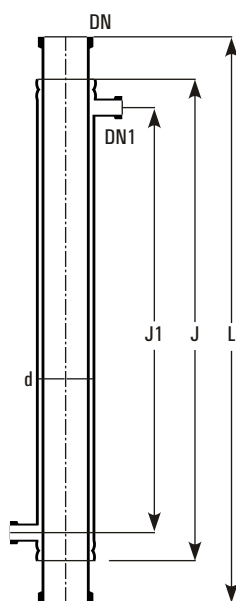

Cat.Ref.	DN	L	d	DN1	J	J1
PSD3/1000	80	1000	100	25	850	750
PSD4/1000	100	1000	150	25	850	750
PSD6/1000	150	1000	225	25	850	700
PSD9/1000	225	1000	300	25	850	700
PSD12/1000	300	1000	400	25	850	650

HOSE CONNECTORS

Cat.Ref.	DN	d	L
PHC0.7/0.75	15	11	70
PHC1/1	25	28	90
PHC1/0.75	25	22	90
PHC1/0.5	25	15	90
PHC1/0.25	25	11	90
PHC1.5/1	40	28	100
PHC1.5/0.75	40	22	100

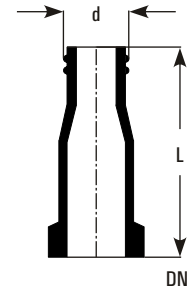

BEND HOSE CONNECTORS

Cat.Ref.	DN	d	L
PBHC0.7/0.75	15	11	50
PBHC1/1	25	28	60
PBHC1/0.75	25	22	60
PBHC1.5/0.75	40	22	75
PBHC2/0.75	50	22	100

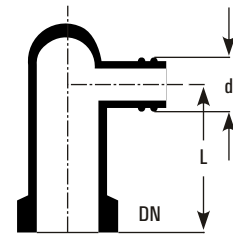

VALVES



A wide variety of valves are described in this section. All the valves are made of Borosilicate Glass body & PTFE plug so that process fluid just comes in contact with Glass & PTFE only. Borosilicate Glass body permits the visual checking of the operation.

All the valves are suitable for operation under full vacuum conditions & a maximum temperature of 200°C.

Borosilicate Valves are available from DN 15 to DN 50.
Bigger size valves are available on request.

STRAIGHT THROUGH VALVES

Cat.Ref.	DN	DN1	d	L	H
PV0.7	15	15	10	125	125
PV1	25	25	18	175	175
PV1.5/1	40	25	18	225	175
PV1.5	40	40	26	225	200
PV2	50	50	38	300	220

Spindles are made of PTFE.

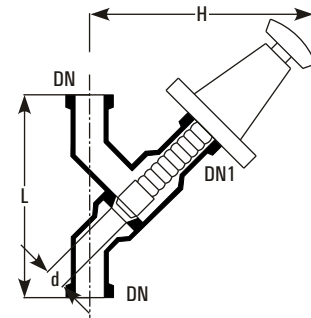

DRAIN VALVES

Cat.Ref.	DN	DN1	d	L	H	D
PVD0.7	15	15	10	125	125	15
PVD1	25	25	18	175	175	28
PVD1.5/1	40	25	18	225	175	28
PVD1.5	40	40	26	225	200	42
PVD2	50	50	38	300	220	50

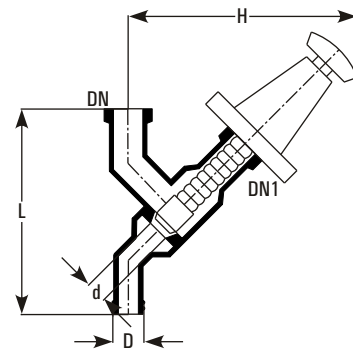

ANGLE VALVES

Cat.Ref.	DN	DN1	d	L	H	Degree
PVE0.7	15	15	10	50	85	90
PVE1	25	25	18	100	175	90
PVE1/80	25	25	18	100	175	80
PVE1.5	40	40	26	150	200	90
PVE2	50	50	38	150	220	90

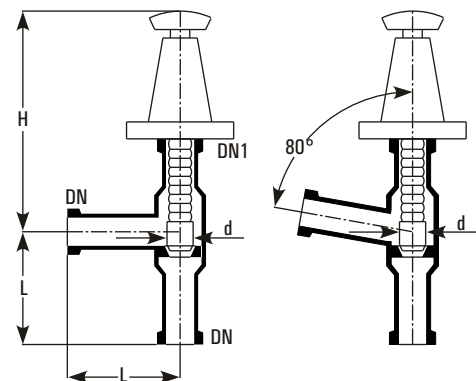

VENT VALVES

Cat.Ref.	DN	D	d	L	L1
PVV0.7	15	11	10	125	-
PVV1	25	11	10	150	85
PVV1.5	40	11	10	150	95

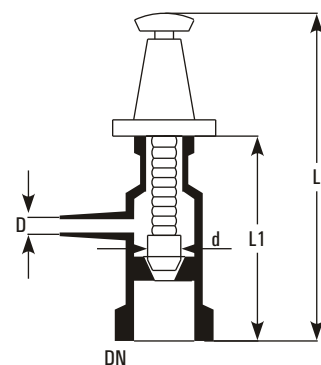

VENT / VACUUM VALVES

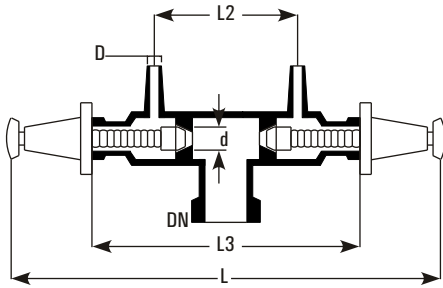

Cat.Ref.	DN	D	d	L	L1	L2	L3
PVW 1/0.7	25	12	10	280	55	85	160
PVW 1.5/0.7	40	12	10	280	65	85	160

BOTTOM OUTLET VALVES

These valves prevent the accumulation of solids or liquid in the bottom outlet of a vessel. This valve can be incorporated in any spherical or cylindrical vessel.

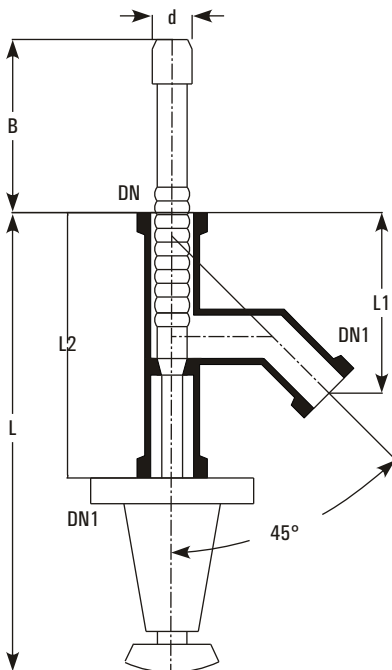

Cat.Ref.	DN	DN1	DN2	d	L	L1	L2	B
BAL1	25	25	25	18	260	105	150	190
BAL1.5	40	25	25	26	260	105	150	190
BAL2	50	40	25	38	260	105	150	190

VESSELS



In most of the glass plants, vessels are used as reactors, receivers, separators, measuring or feed vessels.

Vessels are available in Spherical shape from 5Ltr to 300Ltr. & in cylindrical shape from 5Ltr to 300Ltr capacity.

All the vessels are provided with a bottom outlet for which a suitable valve can be chosen from our range of valves.

SPHERICAL VESSEL - General Data

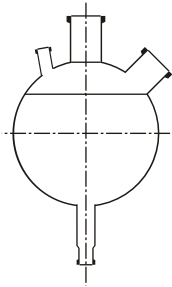

Nominal Capacity (Ltrs.)	Maximum Pressure (Bar)
5	1
10	0.8
20	0.7
50	0.5
100	0.4
200	0.3
300	0.2
500	0.1

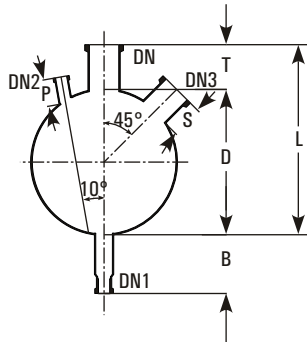

Nominal Capacity (Ltrs.)	L	D	DN	T	DN1	B	DN2	P	DN3	S
5	425	223	50	85	25	125	25	50	40	75
10	500	285	80	100	25	125	25	50	40	75
20	575	350	100	100	25	125	25	50	40	75
50	800	490	150	150	40	200	40	75	100	100
100	900	600	225	150	40	200	40	75	100	100
200	1100	750	300	250	40	200	40	75	100	100
300	1175	860	400	250	50	175	50	75	100	100
500	1400	1000	450	250	50	200	50	75	150	165

SINGLE NECK SPHERICAL VESSELS

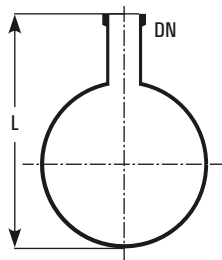

Cat. Ref.	Nominal Capacity	L	DN
VSA5	5 L	300	50
VSA10	10 L	375	80
VSA20	20 L	450	100
VSA50	50 L	600	150
VSA100	100 L	700	225
VSA200	200 L	900	300
VSA300	300 L	1000	400
VSA500	500 L	1200	450

THREE NECK BOTTOM OUTLET SPHERICAL VESSELS

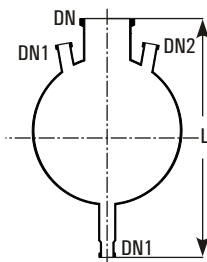

Cat. Ref.	Nominal Capacity	L	DN	DN1	DN2
VSM5	5 L	450	50	25	25
VSM10	10 L	500	80	25	25
VSM20	20 L	575	100	25	25
VSM50	50 L	800	150	40	40
VSM100	100 L	900	225	40	40
VSM200	200 L	1100	300	40	40
VSM300	300 L	1175	400	50	50
VSM500	500 L	1400	450	50	50

FOUR NECK BOTTOM OUTLET SPHERICAL VESSELS

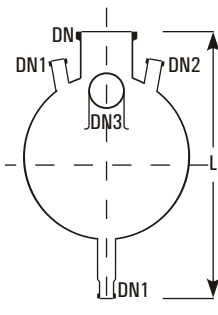

Cat. Ref.	Nominal Capacity	L	DN	DN1	DN2	DN3
VSPL5	5 L	425	50	25	25	40
VSPL10	10 L	500	80	25	25	40
VSPL20	20 L	575	100	25	25	40
VSPL50	50 L	800	150	40	40	100
VSPL100	100 L	900	225	40	40	100
VSPL200	200 L	1100	300	40	40	100
VSPL300	300 L	1175	400	50	50	100
VSPL500	500 L	1400	450	50	50	150

FIVE NECK BOTTOM OUTLET SPHERICAL VESSEL

Cat. Ref.	Nominal Capacity	L	DN	DN1	DN2	Dn3
VSL5	5 L	425	50	25	25	40
VSL10	10 L	500	80	25	25	40
VSL20	20 L	575	100	25	25	40
VSL50	50 L	800	150	40	40	100
VSL100	100 L	900	225	40	40	100
VSL200	200 L	1100	300	40	40	100
VSL300	300 L	1175	400	50	50	100
VSL500	500 L	1400	450	50	50	150

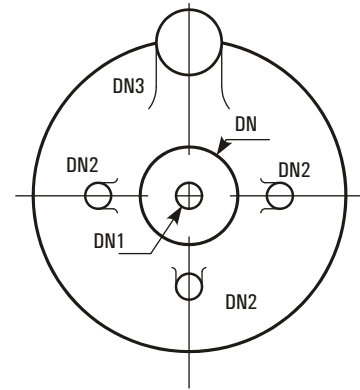

FIVE NECK BOTTOM OUTLET SPHERICAL VESSEL

Cat. Ref.	Nominal Capacity	L	DN	DN1	DN2	Dn3
VS 5	5 L	425	50	25	25	40
VS 10	10 L	500	80	25	25	40
VS 20	20 L	575	100	25	25	40
VS 50	50 L	800	150	40	40	100
VS 100	100 L	900	225	40	40	100
VS 200	200 L	1100	300	40	40	100
VS 300	300 L	1175	400	50	50	100
VS 500	500 L	1400	450	50	50	150

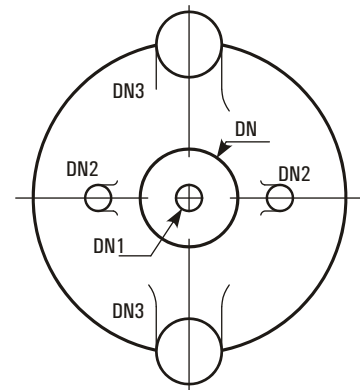

SPHERICAL VESSELS WITH NOZZLE AT 90°

These vessels are used in Circulatory BoilerSystem and are to be supported on a vessel holder. More nozzles can be provided on the equator on request for special requirements.

Cat. Ref.	Nominal Capacity	L	DN	DN1	DN2	Dn3
VSD5	5 L	425	50	25	25	50
VSD10	10 L	500	80	25	25	50
VSD20	20 L	575	100	25	25	50
VSD50	50 L	800	150	40	40	80
VSD100	100 L	900	225	40	40	80
VSD200	200 L	1100	300	40	40	150
VSD300	300 L	1175	400	50	50	150
VSD500	500 L	1400	450	50	50	150

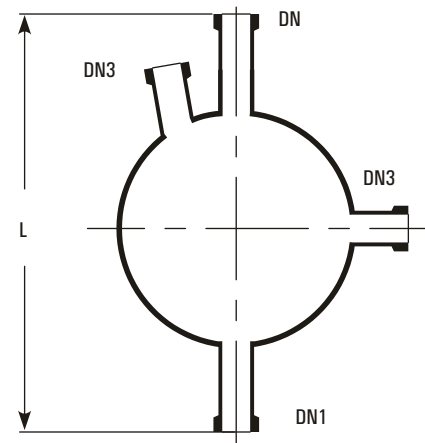

SPHERICAL RECEIVERS

Receivers are provided with builtin drip pipe. These are to be supported on a vessel holding ring.

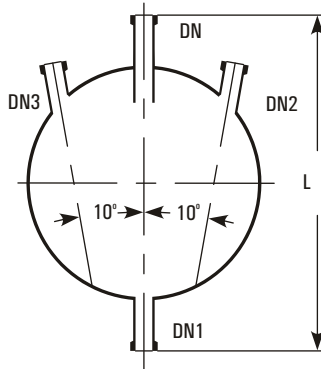

Cat. Ref.	Nominal Capacity	L	DN	DN1	(100) DN2	(100) Dn3
VR5	5 L	350	25	25	25	
VR10	10 L	425	25	25	25	
VR20	20 L	500	25	25	25	
VR50	50 L	675	40	25	25	
VRB5	5 L	350	25	25	25	25
VRB10	10 L	425	25	25	25	25
VRB20	20 L	500	25	25	25	25
VRB50	50 L	675	40	25	25	25

ADDITION VESSELS

These vessels are provided with a short bottom outlet. These should be supported on a vessel holder/ holding ring.

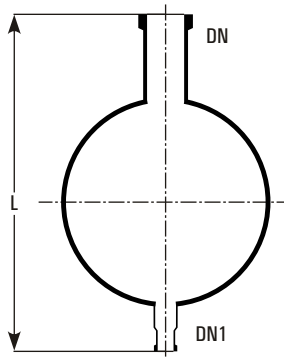

Cat. Ref.	Nominal Capacity	L	DN	DN1
VA5	5 L	375	360	50
VA10	10 L	435	80	25
VA20	20 L	510	100	25
VA50	50 L	675	150	40
VA100	100 L	775	225	40
VA200	200 L	975	300	40
VA300	300 L	1075	400	50
VA500	500 L	1400	450	50

SPHERICAL VESSELS WITH WIDE BOTTOM OUTLET

These vessels are generally used to fit immersion exchangers in the bottom. Special heating mantle or bath should be used if used with.

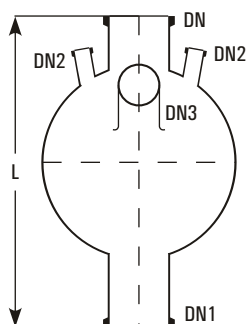

Cat. Ref.	Nominal Capacity	L	DN	DN1	DN2	Dn3
VSR50	50 L	750	150	150	40	100
VSR100	100 L	850	225	150	40	100
VSR200	200 L	1050	300	150	40	100
VSE50	50 L	800	150	225	40	100
VSE100	100 L	900	225	225	40	100
VSE200	200 L	1100	300	225	40	100

CYLINDRICAL VESSELS

Cat. Ref.	Nominal Capacity	DN	DN1	L	L1
VZ5/4	5 L	100	25	700	175
VZ10/6	10 L	150	25	700	175
VZ20/9	20 L	225	25	750	175
VZ50/12	50 L	300	40	1000	175
VZ100/18	100 L	450	40	900	175
VZ150/16	150 L	400	40	1400	175
VZ200/18	200 L	450	40	1500	175
VZ300/24	300 L	600	50	1300	175

Cylindrical vessels of 50 Litres and above must be supported in a vessel holder.

Other accessories, like stirrers, baths, vessel holders etc, for cylindrical vessels can be supplied to special orders.

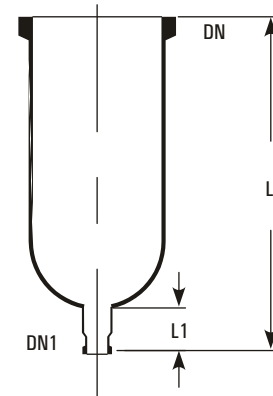

CYLINDRICAL VESSEL COVERS

Cat. Ref.	DN	DN1	DN2	L
VZA4	100	-	2x25	200
VZA6	150	-	2x40	200
VZA9	225	50	3x25	250
VZA12	300	80	3x40	250
VZA16	400	100	3x40	275
VZA18	450	100	4x40	275
VZA24	600	100	4x40	300

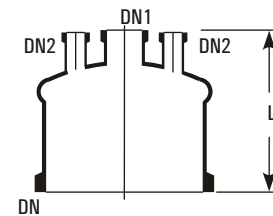

KETTLES

Kettles are similar to cylindrical vessels but having a reduced top neck.

Cat. Ref.	Nominal Capacity	DN	DN1	L	L1	d
KZ200	200 L	300	40	1400	175	485
KZ350	350 L	400	50	1500	175	620

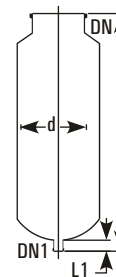

JACKETED VESSELS

For special applications, cylindrical vessels can be supplied with a jacket for heating or cooling. Jacket is sealed to the vessel with Viton 'O' ring and other sealing compositions. The seal prevents high stresses between vessel and jacket by allowing the movement flexibility between two due to thermal expansion.

Glass Jackets

Glass Jacket can be used for a maximum operating pressure of 0.5 bar and a maximum operating temperature of 130°C in jacket. The temperature difference between jacket & vessel should not be exceed than 120°C

Cat. Ref.	L	L1	L2	A	B	D1	D2	DN	DN1	DN2	TYPE
VZD5/6	500	325	125	75	275	165	215	150	25	25	A
VZD10/9	575	400	125	90	340	230	280	225	25	25	B
VZD20/12	625	450	125	100	385	315	370	300	25	40	B
VZD30/12	750	575	175	100	510	315	370	300	25	40	B
VZD50/12/14	1050	875	175	-	-	315	365	300	25	40	C
VZD50/16/20	825	650	175	-	-	415	500	400	25	40	C
VZD100/20/24	955	780	175	-	-	516	600	500	25	40	C

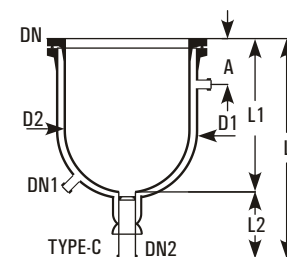

DIP PIPES

Dip pipes are used as liquid inlet for spherical vessels.

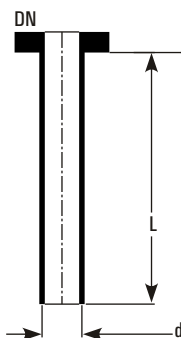

Cat. Ref.	For Vessel	DN	DN1	d	L
DP20/1	20 L	25	25	12	300
DP50/1.5	50 L	40	25	19	400
DP100/1.5	100 L	40	25	19	500
DP200/1.5	200 L	40	25	19	600

SHORT DIP PIPES

Short dip pipes are used as re-entry tubes for vessels, heat exchangers etc.

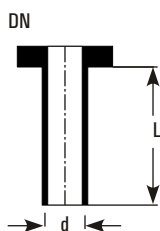

Cat.Ref.	DN	DN1	d	L	L1
DP1/1	25	25	12	100	100
DP1.5/1	40	25	19	100	100
DP1.5/1.5	40	40	19	100	100
DP2/1	50	25	25	100	100
DP2/1.5	50	40	25	100	100
DP3/1.5	80	40	37	100	125
DP4/1	100	25	25	100	150
DP4/2	100	50	50	100	150

GAS SPARGERS

Gas spargers are used for gas feed/sparging in the vessels.

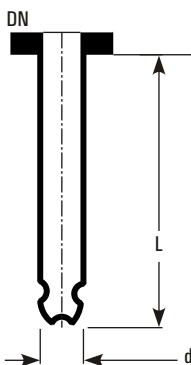

Cat.Ref.	For Vessel	DN	DN1	d	L	No. of Holes
SPG20/1	20 L	25	25	12	300	5x1mm
SPG50/1.5	50 L	40	25	19	400	5x1mm
SPG100/1.5	100 L	40	25	19	500	5x1mm
SPG200/1.5	200 L	40	25	19	600	5x1mm

THERMOMETER POCKETS

Cat. Ref.	For Vessel	DN	d	L
TP20/1	20 L	25	12	300
TP50/1.5	50 L	40	19	400
TP100/1.5	100 L	40	19	500
TP200/1.5	200 L	40	19	600

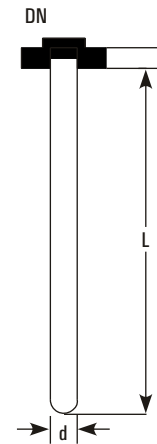

HEATING MANTLES

Heating Mantle is used for electrical heating of cylindrical as well as spherical vessels. Also available in flameproof & non-flame proof models. The flameproof heating mantle is similar to normal mantle but the main difference is in construction of heating elements. Heating elements is flameproof by covering it in magnesium oxide powder & SS metal tube. Heater terminal terminate in flameproof cold junction terminal enclosure. All electrical control like regulator, switch, indicating lamp, relay etc. fitted in flameproof switch enclosure.

We can also provide flameproof digital temperature indicator cum controller with sensor.

Cat. Ref.	Vessel Size	D	L	Watts	Circuits	Supply Volts
JMD5	5 L	320	190	750	1	230
JMD10	10 L	380	220	1200	2	230
JMD20	20 L	485	285	2000	3	230
JMD50	50 L	600	345	3700	3	415
JMD100	100 L	790	470	6000	3	415
JMD200	200 L	920	530	7500	3	415

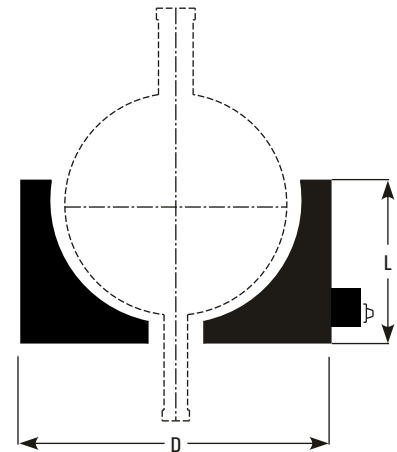

Cat. Ref.	Vessel Size	D	L	Watts	Circuits	Supply Volts
JMD5/F	5 L	330	200	600	1	230
JMD10/F	10 L	440	220	1000	2	230
JMD20/F	20 L	510	285	2000	3	230
JMD50/F	50 L	610	350	3600	3	415
JMD100/F	100 L	790	430	5200	3	415
JMD 200/F	200 L	940	510	8400	3	415

HEATING BATHS

Heating baths are used for electrical or steam heating of glass vessels. Depending upon the temperature requirements, different types of thermic fluids or water can be used as heating media. Heating baths are provided with a pair of encased heaters with controller box, a coil for passing the steam or cooling water, a cushioned vessel holding ring, a bottom outlet sealing arrangement, a lid and threaded socket type inlets and outlets.

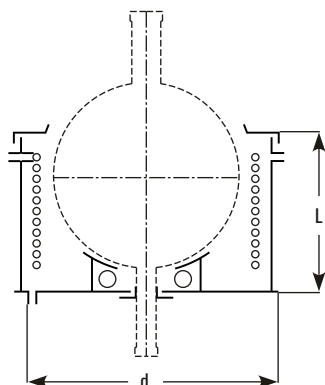

Cat.Ref.	Vessel Size	d	L	Watts	HTA Vessel	HTA Coils
SBH20	20 L	480	340	2x2000	0.25	0.4
SBH50	50 L	615	415	2x3000	0.5	0.6
SBH100	100 L	720	535	2x4000	0.7	1
SBH200	200 L	900	620	2x5000	1	1.5
SBH300	300 L	1150	735	3x5000	1.85	2.5
SBH500	500 L	1385	880	4x5000	2.5	4.0

COOLING BATHS

Cooling baths are used for cooling the glass vessel with ice crystals. Cooling Baths are provided with a vessel holding ring, bottom outlet sealing arrangement and a lid.

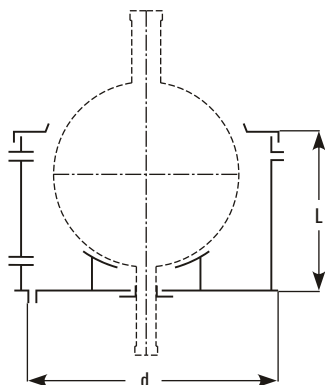

Cat.Ref.	Vessel Size	d	L
BHC20	20 L	480	340
BHC50	50 L	615	415
BHC100	100 L	720	535
BHC200	200 L	900	620

VESSEL HOLDERS

Vessel holders are made of cast aluminum with a plaster lining shaped to fit the vessel. These are to be supported on 3 jacking bolts.

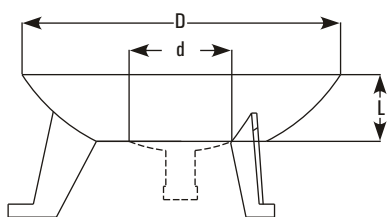

Cat.Ref.	Vessel Size	D	d	L
VSS20	20 L	325	230	100
VSS50	50 L	390	230	100
VSS100	100 L	410	250	100
VSS200	200 L	700	400	215

VESSEL HOLDING RINGS

These metal rings are wrapped with asbestos rope and are to be supported on two jacking bolts.

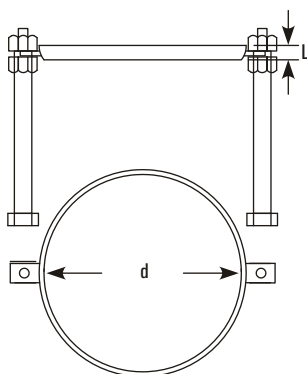

Cat.Ref.	Vessel Size	d	L
VRS2	2 L	100	15
VRS5	5 L	150	15
VRS10	10 L	215	15

STIRRERS

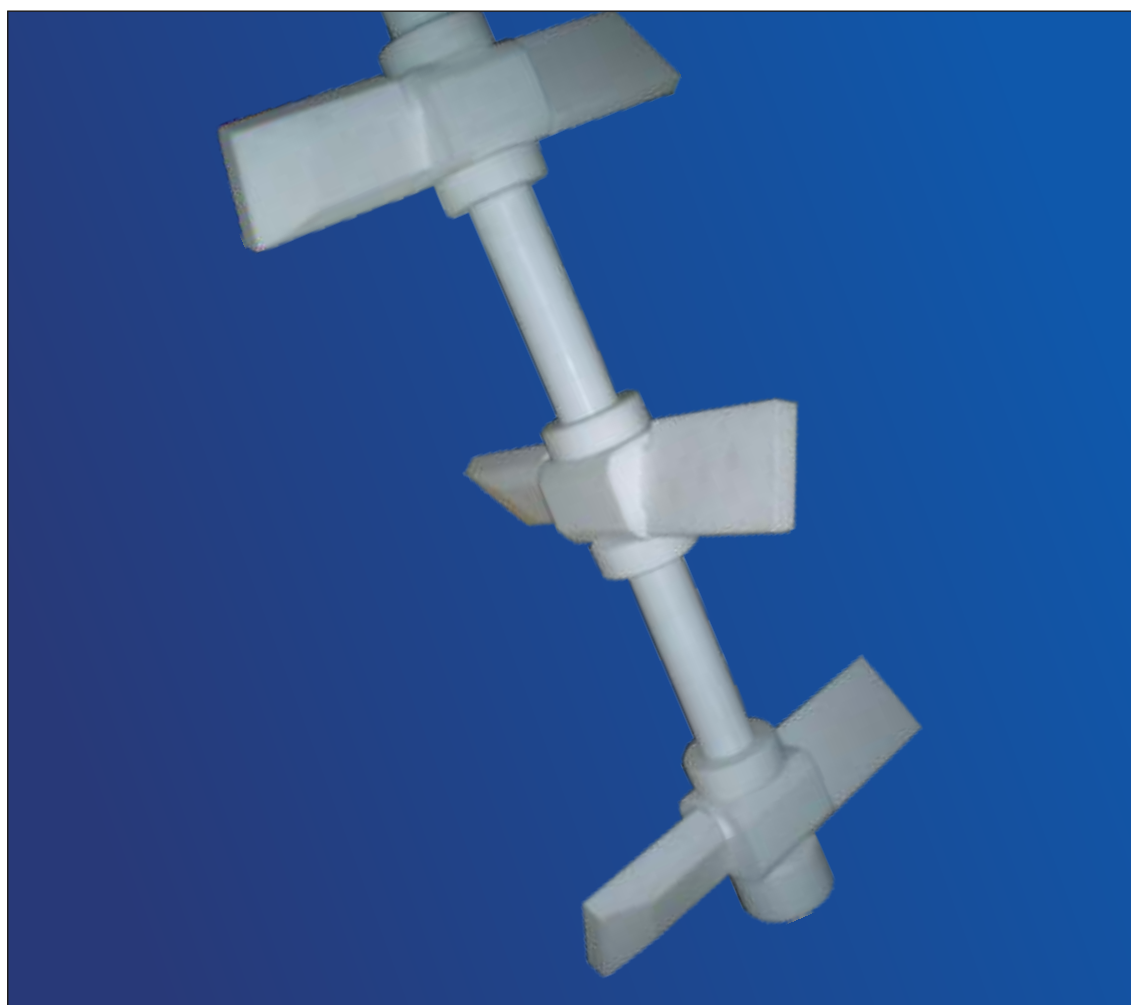

A variety of stirrer & stirrer drives are available to use glass vessels as agitated reaction equipment.

1. Stirrer material of construction: Glass, Stainless Steel or PTFE Lined.
2. Stirrer Design: Impeller stirrer with blades, Vortex stirrer, Propeller Stirrer & anchor Stirrer.
3. Stirring Drive: Non-flameproof or Flameproof stirrer drive, 192 RPM with Variable Frequency Drive.
4. Stirring Assembly: Stirring Assembly with bellow seal or with mechanical seal.

STIRRERS

Stirrers are assembled in a vessel using a chuck, seal & a reducer. A typical arrangement of stirrer fitted in a vessel is shown in the diagram.

Size	A	B	C	D	L
20 L	250	150	450	25	825
50 L	300	200	600	50	1050
100 L	300	250	700	50	1200
200 L	300	300	900	50	1450
300L	300	25	1000	50	1275

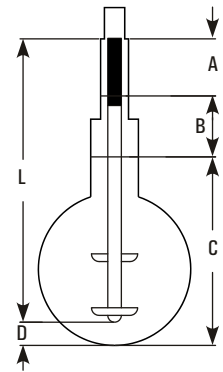

CHUCK & SEAL

This unit is suitable for use under corrosive conditions. Only glass and PTFE are exposed to process fluids. Bellow seal can be used under vacuum down to 10mm Hg absolute. Mechanical seal can be used under vacuum 1mm Hg absolute or under pressure permitted into glass vessels. Generally a reducer is required to connect the chuck and seal to top neck of the vessel.

Cat.Ref. Bellow Seal	Cat.Ref. Mechanical Seal	Vessel	DN	L	L1	d
CSA1	CSM1	20 L	50	300	250	25
CSA1.5	CSM1.5	50,100, 200 L	80	360	300	47

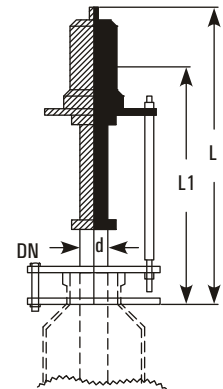

STIRRER WITH TEFLON BLADES

These stirrers are used with liquid of low viscosity.

Cat.Ref.	Vessel	L	L1	L2	L3	d	D
STB10	10	600	300	15	175	25	100
STB20	20	825	300	25	200	25	100
STB50	50	1050	300	25	200	47	150
STB100	100	1200	300	30	250	47	175
STB200	200	1450	300	30	325	47	200
STB300	300	1275	350	30	425	59	275

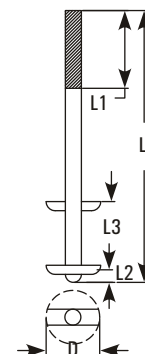

STIRRING ASSEMBLY WITH BELLOW SEAL

A stirrer is assembled in chuck with bellow seal and appropriate reducer. This assembly is convenient to install on a vessel. The assembly consist of :

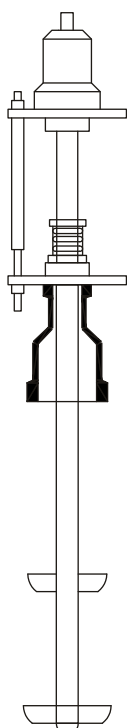

- | | |
|----------------------------|-------------|
| a. Glass stirrer | STB/STV/STP |
| b. Chuck and seal assembly | CSA |
| c. Reducer | PR |

Cat. Ref.	For Vessel	Stirrer Used	Chuck & Seal	Reducer Used
STBA20	20L	STB20	CSA1	PR4/2
STBA50	50L	STB50	CSA1.5	PR6/3
STBA100	100L	STB100	CSA1.5	PR9/3
STBA200	200L	STB200	CSA1.5	PR12/3
STBA300	300L	STB300	CSA2	PR16/4
STVA50	50L	STV50	CSA1.5	PR6/3
STVA100	100L	STV100	CSA1.5	PR9/3
STVA200	200L	STV200	CSA1.5	PR12/3
STVA300	300L	STV300	CSA2	PR16/4
STPA50	50L	STP50	CSA1.5	PR6/3
STPA100	100L	STP100	CSA1.5	PR9/3
STPA200	200L	STP200	CSA1.5	PR12/3
STPA300	300L	STP300	CSA2	PR16/4

STIRRING ASSEMBLY WITH MECHANICAL SEAL

A stirrer is assembled in chuck with mechanical seal and appropriate reducer. This assembly is convenient to install on a vessel. The assembly consist of :

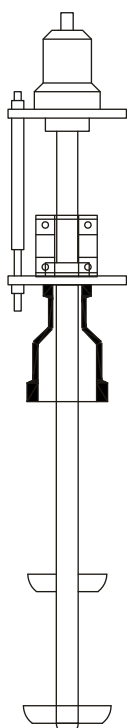

- | | |
|------------------------------|-------------|
| a. Glass stirrer | STB/STV/STP |
| b. Chuck and mechanical seal | CSM |
| c. Reducer | PR |

Cat. Ref.	For Vessel	Stirrer Used	Chuck & Seal	Reducer Used
STBM20	20L	STB20	CSA1	PR4/2
STBM50	50L	STB50	CSA1.5	PR6/3
STBM100	100L	STB100	CSA1.5	PR9/3
STBM200	200L	STB200	CSA1.5	PR12/3
STBM300	300L	STB300	CSA2	PR16/4
STVM50	50L	STV50	CSA1.5	PR6/3
STVM100	100L	STV100	CSA1.5	PR9/3
STVM200	200L	STV200	CSA1.5	PR12/3
STVM300	300L	STV300	CSA2	PR16/4
STPM50	50L	STP50	CSA1.5	PR6/3
STPM100	100L	STP100	CSA1.5	PR9/3
STPM200	200L	STP200	CSA1.5	PR12/3
STPM300	300L	STP300	CSA2	PR16/4

HEAT EXCHANGERS



The overall heat transfer co-efficient of Borosilicate glass equipment is comparatively favourable with many alternative materials because of its smooth surface which improves the thermal coefficient & reduce the tendency of fouling.

Heat Exchangers are available in 2 basics designs:

1. Conventional Coil Type Condensers.
2. Shell & Tube Type.

SHELL AND TUBE HEAT EXCHANGERS

INTRODUCTION

Shell & tube heat exchangers offer large surface area in combination with efficient heat transfer and compactness. These are widely used in industries for various duties like cooling, heating, condensation, evaporation etc. We are the pioneers in the field of glass shell and tube heat exchangers in India and their product has a wide market acceptability.

SALIENT FEATURES

1. Universal corrosion resistance an excellent alternative to expensive MOCs like graphite, hastelloy, copper titanium, tantalum and other exotic metals.
2. Excellent heat transfer as fouling does not occur on smooth glass surfaces.
3. Flexibility of installation vertical / horizontal.
4. Easy replacement of tubes for repair and cleaning.
5. Available in wide range of HTAs.
6. Ease of installation due to light weight.
7. Economical.
8. Suitable for applications where large HTAs are required in limited space.

ADVANTAGES OVER CONVENTIONAL COIL TYPE HEAT EXCHANGERS

- (1) The overall heat transfer coefficient in shell and tube heat exchanger is about 3 times higher than in coil type heat exchanger.
- (2) The pressure drop in shell and tube heat exchanger is minimal compared to 2-3 kg/cm² in coil side of coil type heat exchanger.
- (3) For requirement of higher heat transfer areas shell and tube heat exchanger is the only alternative.

CONSTRUCTION FEATURES

The glass tubes are sealed individually into PTFE tube sheet with special PTFE sockets and packing. This unique ferrule type sealing arrangement permits easy replacement and cleaning of tubes. Baffles on shell side ensure improved heat transfer by increased turbulence. Further details of construction can be seen in the diagram.

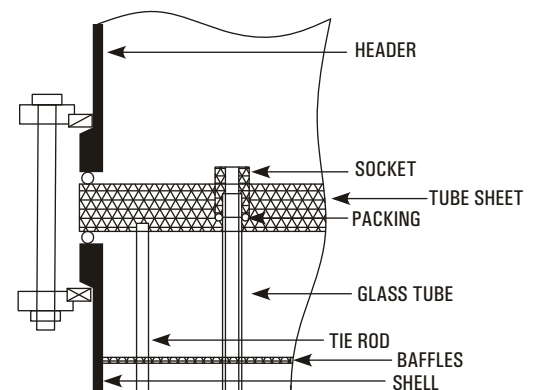

DIMENSIONAL SPECIFICATIONS

Cat. Ref. RGG/RMG	6/3	6/4	6/5	6/6	9/6	9/8	9/10	9/12	12/12	12/16	12/21	12/25
Area (m ²)	3	4	5	6	6	8	10	12	12	16	21	25
DN	150				225				300			
DN1	80				100				150			
DN2	50				80				80			
DN3	25				40				40			
DN4	50				50				50			
H1	175				250				300			
H2	150				200				250			
L	2500	3100	3700	4300	2620	3220	3820	4520	2550	3150	3950	4550
L1	1900	2500	3100	3700	1900	2500	3100	3800	1800	2400	3200	3800
L2	150	150	150	150	225	225	225	225	225	225	225	225
L3	1600	2200	2800	3400	1450	2050	2650	3350	1350	1950	2750	3350
L4	250	250	250	250	300	300	300	300	300	300	300	300
L5	125	125	125	125	175	175	175	175	175	175	175	175
L6	1980	2580	3180	3780	2000	2600	3200	3900	1930	2530	3330	3930
T	50				60				75			
No. of Tubes	37				73				151			
No. of Baffles	11	15	19	23	7	9	13	17	5	7	9	11

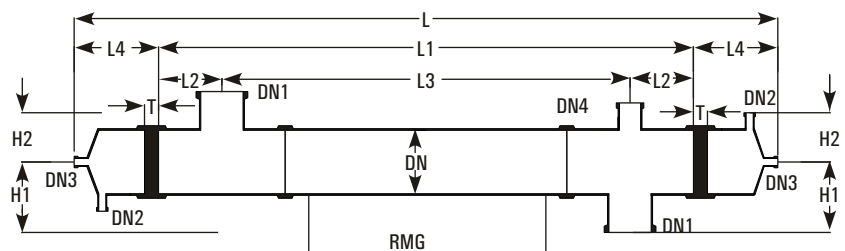
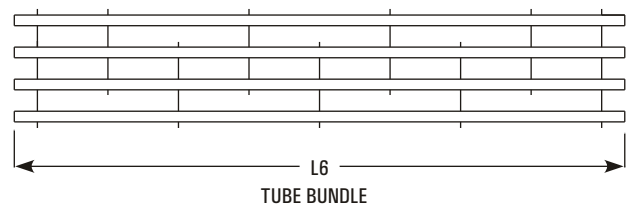
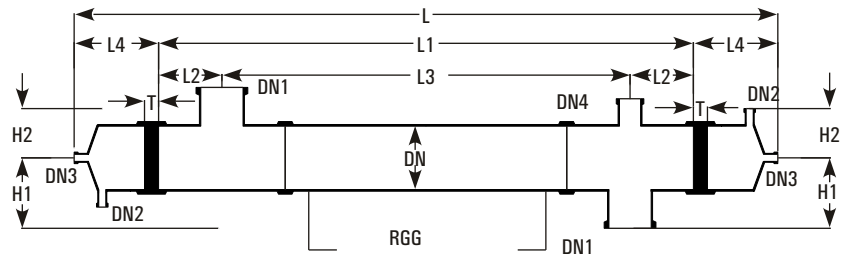

CONDENSERS

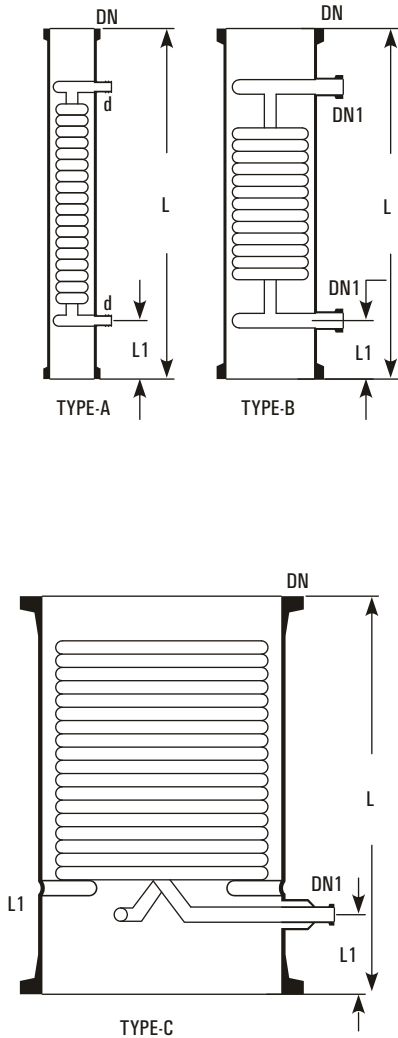

Condensers are used for condensation of vapours and cooling of liquids. Condensers are made by fusing number of parallel coils in a glass shell. Coils are made in different diameters using tubes of different bores.

The average co-efficient of heat transfer in coil condenser is considered as-

Condensation	200 - 270 Kcal/m ² ,hr,°C appx.
Cooling	100 - 150 Kcal/m ² ,hr,°C appx.

Cat. Ref.	DN	d/ DN1	L	L1	Type	Actual H.T.A. m ²	Cross Area Cm ²	Free Coolant Rate Kg/hr.	Max. Jacket Cap. Litre
HE3/3.5	80	16	600	75	A	0.35	5	1300	2
HE4/5	100	19	600	75	A	0.50	30	2400	4
HE4/6	100	19	750	100	A	0.60	30	2400	6
HE6/10	150	25	600	100	B	1.00	52	2600	9
HE6/15	150	25	850	100	B	1.50	52	2600	11
HE9/25	225	25	800	110	B	2.50	125	3300	18
HE12/25	300	25	600	125	B	2.50	175	5700	25
HE12/40	300	25	900	125	B	4.00	175	5700	35
HE16/40	400	25	600	125	B	4.00	450	6200	60
HE16/50	400	25	700	125	B	5.00	450	6200	70
HE18/60	450	40	750	150	C	6.00	820	4800	100
HE18/80	450	40	900	150	C	8.00	820	6200	110

Precautions to be taken in use of condensers

- Vapours should be passed through shell only.
- Maximum pressure of coolant should be 2.7 bars.
- Adequate flow of coolant should be used.
- Steam should not be used in coils.
- Coolant should not be heated to boiling point.
- Coolant control valve should be turned slowly.
- Coolant should be allowed to drain freely.
- Brine can be used in coils in a closed circuit.
- Water main should be connected with flexible hose.
- Ensure no freezing of water remaining in the coils.
- Condensers should be mounted vertically only.
- Condensers can be mounted in series to provide larger surface area.

PRODUCT COOLERS

Product coolers are used for cooling of liquids, typically, for the cooling of distillates from the distillation columns.

Unlike coil condensers, in product coolers, product travels through the coil battery and coolant through shell. This provides more resident time to the product to be cooled. For direct connection with distillate lines, all the product coolers are provided with 25 DN connections.

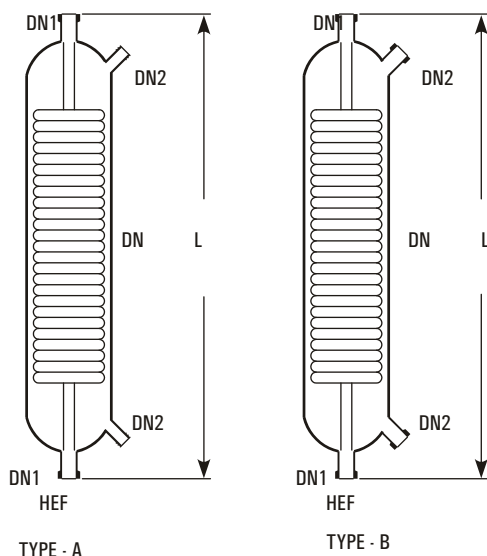

Cat.Ref.	DN	DN1	DN2	L	Actual HTA m ²	Type
HEF1/1	50	25	12	450	0.1	A
HEF1/2	50	25	12	600	0.2	A
HEF1/3.5	80	25	16	600	0.35	A
HEF1/5	100	25	19	600	0.5	A
HEF1/10	150	25	25	600	0.7	B
HEF1/15	150	25	25	850	1.25	B

BOILERS

Boilers are used for vaporization of liquids by passing the steam in the coils. Boilers are made by fusing number of parallel coils in a glass shell. In Boilers, coils are designed to provide bigger cross section in the shell side as compared to condensers.

The average heat transfer in Boilers is considered as 350 Kcal/m²,hr,°C at a steam pressure of 3.5 bar.

Cat. Ref.	DN	DN1	DN2	L	L1	Type	Actual H.T.A. m ²	Free Cross Area Cm ²	Jacket Cap. Litre
HEB4	100	25	25	375	100	A	0.15	40	2
HEB4/4	100	100	25	400	100	B	0.15	40	3
HEB6	150	40	25	450	100	A	0.35	50	5
HEB6/6	150	150	25	500	100	B	0.35	50	7
HEB9	225	40	25	700	100	A	1.00	150	16
HEB9/9	225	225	25	700	100	B	1.00	180	20
HEB12/12	300	300	25	700	125	B	1.30	330	40

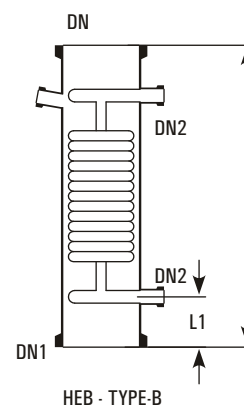

Notes on use of Boilers :

- Steam should be passed in the coils at a maximum pressure of 3.5 bar which is equalant to a temperature of 147°C.
- For higher temperature (maximum upto 200°C) heat transfer fluids can be passed in the coils. - Cold liquids
- Cold liquids should be preheated for better results.
- Boilers should be mounted in an external circulatory loop (as shown in figure) and not direct at the bottom of flask or column
- Under certain circumstances, boilers can be mounted in series to provide larger heat transfer area.

IMMERSIONS

Immersion heat exchangers are used to control exothermic reaction in glass vessels. They can be used with vessels having wider bottom outlet (type VSR and VSE). These are provided with a central hole through the coil battery so that a special, extended type, stirrer can be fitted which extends to the bottom of heat exchanger and provide through action.

In most applications, cooling water is used in coils (max. pressure 2.7 bar g.), but they can also be used with steam (max. pressure 3.5 bar g.). In latter case the coils must be completely immersed in liquid. Immersions are not recommended for use with products which have a tendency to crystallise.

Cat. Ref.	DN	DN1	DN2	L	L1	L2	d	Actual H.T.A. m ²
HEM6	150	40	25	200	200	75	145	0.4
HEM9	225	40	25	300	200	75	200	0.6

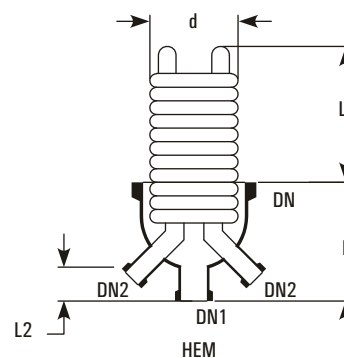

COLUMN COMPONENTS



In many operations like reaction, extraction & absorption, the transparency of glass is particular advantage. For such process a range of column components are available in Borosilicate glass which offers many advantages like:

1. Inert to almost all chemicals hence no risk of contamination.
2. Transparency allows visual monitoring of the process flow patterns, colour changes etc.
3. Almost universal resistance to corrosion.
4. Smooth surface permits easy cleaning & prevents fouling.

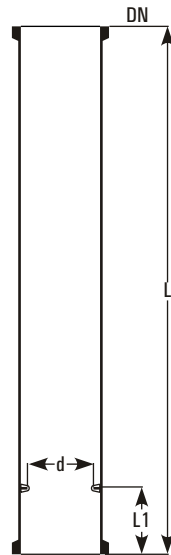

COLUMN SECTIONS

COLUMN SECTIONS

Column can be constructed either by using pipe sections with support plates or using column sections with packing supports.

Column sections are provided with fused shelf where packing support can rest.

Cat.Ref.	DN	L	L1	Minimum packing Size	Usual packing Size
CS3/1000	80	1000	75	9	12
CS4/1000	100	1000	75	12	15
CS6/1000	150	1000	75	15	25
CS6/1500	150	1500	75	15	25
CS9/1000	225	1000	100	20	25
CS9/1500	225	1500	100	20	25
CS12/1000	300	1000	125	25	25
CS12/1500	300	1500	125	25	25
CS16/1000	400	1000	150	25	25
CS16/1500	400	1500	150	25	25
CS18/1000	450	1000	150	25	25
CS18/1500	450	1500	150	25	25

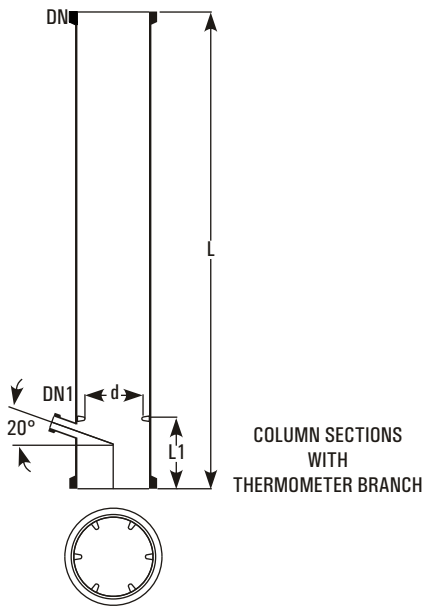

COLUMN SECTIONS WITH THERMOMETER BRANCH

COLUMN SECTIONS WITH THERMOMETER BRANCH

Above column sections can be provided with a thermometer branch below the packing shelf at 20° slope

Cat.Ref.	DN	DN1	L	L1	d
CST3/1000	80	25	1000	125	50
CST4/1000	100	25	1000	125	75
CST6/1000	150	25	1000	125	125
CST6/1500	150	25	1500	125	125
CST9/1000	225	25	1000	150	175
CST9/1500	225	25	1500	150	175
CST12/1000	300	25	1000	150	250
CST12/1500	300	25	1500	150	250
CST16/1000	400	25	1000	200	250
CST16/1500	400	25	1500	200	350
CST18/1000	450	25	1000	200	400
CST18/1500	450	25	1500	200	400

PACKING SUPPORTS

Packing supports Type A are made of fused glass rods. Packing supports Type B (heavy duty) are made of glass plates vertically arranged and tied with PTFE tie rods.

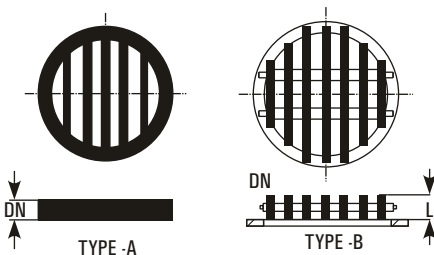

Section Kgs.	Load Size	Packing Type	Cross Cat.Ref.	Max. DN	Minimum L	Area
CP3	80	10	45%	10	12	A
CP4	100	12	50%	15	15	A
CP6	150	15	55%	30	25	A
CP9	225	19	60%	50	25	A
CP12	300	19	65%	75	25	A

COLUMN FEED PIPE

Feed pipe directs the process fluid to the centre of the column.

Cat.Ref.	DN	DN1	DN2	L	d
FP3	80	25	25	100	12
FP4	100	25	25	125	12
FP6	150	40	25	150	19
FP9	225	40	25	175	19
FP12	300	40	25	225	19
FP16	400	40	25	275	19
FP18	450	40	25	300	19
FP24	600	50	40	450	25

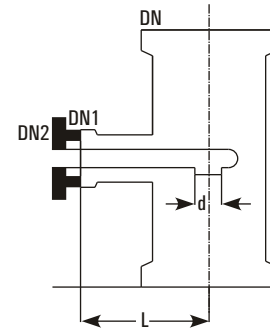

DN refers the nominal diameter of the column.

COLUMN FEED SPARGERS

In column feed spargers, holes are provided at three sides of pipe.

Cat.Ref.	DN	DN1	DN2	L	Holes
SPG3	80	25	25	125	21x2mm
SPG4	100	25	25	150	21x2mm
SPG6	150	40	25	200	27x2mm
SPG9	225	40	25	275	27x2mm
SPG12	300	40	25	350	30x3mm
SPG16	400	40	25	450	39x3mm
SPG18	450	40	25	500	39x3mm
SPG24	600	50	40	650	60x3mm

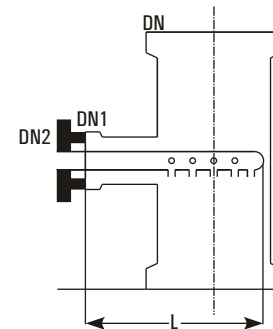

DN refers the nominal diameter of the column.

COLUMN PACKING-RASCHIG RINGS

Raschig rings upto 25mm are made from Neutral glass. 40mm and 50mm raschig rings are available only in Borosilicate glass.

Cat.Ref.	Size	Glass
FCB20	20x20	Borosilicate
FCB25	25x25	Borosilicate
FCB30	30x30	Borosilicate
FCB40	40x40	Borosilicate
FCB50	50x50	Borosilicate



Packings require for various pipe sections (Kgs.)

Pipe Section	Packing size						
	Vol (L)	FC	FC 12	FC 15	FC 25	FCB 40	FCB 50
PS3/1000	5	3	3	2	-	-	-
PS4/1000	8	-	4	3	3	-	-
PS6/1000	18	-	9	7	7	-	-
PS9/1000	37	-	-	15	15	15	-
PS12/1000	66	-	-	17	30	25	-
PS16/1000	125	-	-	-	65	50	53
PS18/1000	165	-	-	-	90	65	70
PS24/1000	295	-	-	-	-	115	125

Notes of use of Column Packing

- Due to their low bulk densities, Glass Raschig rings are particularly suitable for packing glass columns.
- Generally, the ratio of Column diameter to packing diameter should not be less than 8:1.
- When using smaller packing size, a small layer of larger packing should be used on packing support, to prevent the smaller packing falling through.
- In vacuum application and applications involving high vapour velocities, packing may be lifted and may damage to other parts. To prevent this, a packing retainer (PTFE perforated plates) should be used above the packed section.

PALL RINGS

Pall Rings are also available for column packing as per below specification.

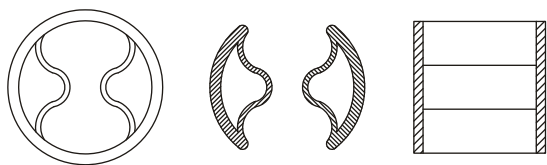

Cat.Ref.	Size	Bulk Density Kg/Ltr	Specific Surface m ² /m ³	Glass
FCP30	30x30	0.3	234	Borosilicate
FCP40	40x40	0.3	187	Borosilicate
FCP50	50x50	0.32	140	Borosilicate

COLUMN ADAPTORS

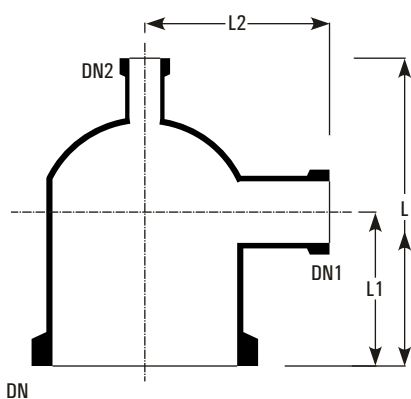

Cat.Ref.	DN	DN1	DN2	L	L1	L2
CA3/1/1	80	25	25	150	75	100
CA3/1.5/1	80	40	25	175	100	100
CA3/2/1	80	50	25	175	100	100
CA4/1/1	100	25	25	150	75	125
CA4/1.5/1	100	40	25	175	100	125
CA4/2/1	100	50	25	225	125	125
CA4/3/1	100	80	25	225	125	125
CA6/1/1	150	25	25	200	100	150
CA6/1.5/1	150	40	25	200	100	150
CA6/2/1	150	50	25	250	125	150
CA6/3/1	150	80	25	250	150	150
CA6/4/1	150	100	25	275	150	175
CA9/1.5/1.5	225	40	40	250	150	175
CA9/2/1.5	225	50	40	250	150	175
CA9/3/1.5	225	80	40	300	175	200
CA9/4/1.5	225	100	40	350	175	200
CA9/6/1.5	225	150	40	400	200	250
CA12/1.5/1.5	300	40	40	300	150	225
CA12/2/1.5	300	50	40	300	150	225
CA12/3/1.5	300	80	40	300	150	250
CA12/4/1.5	300	100	40	350	175	250
CA12/6/1.5	300	150	40	425	225	250
CA12/9/1.5	300	225	40	450	225	300
CA16/2/2	400	50	50	400	200	300
CA16/3/2	400	80	50	450	250	300
CA16/4/2	400	100	50	450	250	300
CA16/6/2	400	150	50	550	300	350
CA16/9/2	400	225	50	550	300	350
CA18/2/2	450	50	50	400	200	325
CA18/3/2	450	80	50	450	250	350
CA18/4/2	450	100	50	450	250	350
CA18/6/2	450	150	50	550	300	350
CA18/9/2	450	225	50	550	300	400
CA18/12/2	450	300	50	750	400	400

Column adaptors with DN2 of different size(maximum equaling to DN1) can be manufactured with the same dimensions.

FLAT TOP COLUMN ADAPTORS

These are generally used as headers of shell and tube heat exchangers and columns.

Cat.Ref.	DN	DN1	L	L1
CA3/1	80	25	100	75
CA3/1.5	80	40	125	100
CA4/1	100	25	100	75
CA4/1.5	100	40	125	100
CA6/1	150	25	150	100
CA6/1.5	150	40	150	100
CA6/2	150	50	200	125
CA6/3	150	80	200	150
CA6/4	150	100	250	150
CA9/1.5	225	40	200	150
CA9/2	225	50	200	150
CA9/3	225	80	250	175
CA9/4	225	100	250	175
CA9/6	225	150	300	175
CA12/2	300	50	250	150
CA12/3	300	80	250	150
CA12/4	300	100	300	175
CA12/6	300	150	350	225
CA12/9	300	225	400	225

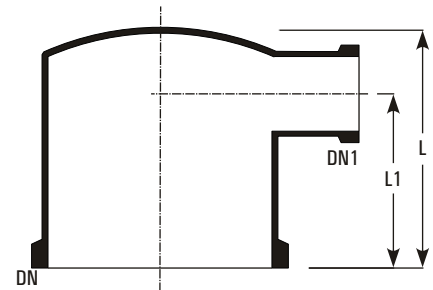

Cat.Ref.	DN	DN1	DN2	L	L1	L2	L3	L4	L5
CAM4/2/1/1	100	50	25	450	300	150	200	125	125
CAM6/3/1/1	150	80	25	450	300	150	200	150	150
CAM9/3/1.5/1.5	225	80	40	450	300	150	200	175	200
CAM12/3/1.5/1.5	300	80	40	450	300	150	200	225	250

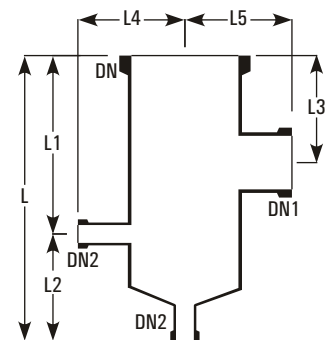

REFLUX DIVIDERS

Manually Operated

Reflux dividers are used to take off the distillate from the column. Usually a valve is to be fitted on distillate outlet which controls the reflux coarsely.

Cat.Ref.	DN	DN1	DN2	L	L1	Free Corss Section Cm2	Max. Product L/hr
RDA3	80	25	25	200	100	20	300
RDA4	100	25	25	250	150	50	500
RDA6	150	25	25	250	150	100	700
RDA9	225	25	25	375	150	150	900
RDA12	300	25	25	375	150	250	1100
RDA16	400	40	40	500	200	350	1300
RDA18	450	40	40	600	275	500	1500

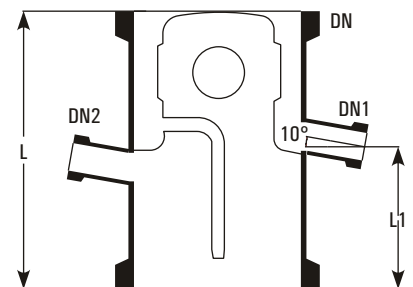

DN2 is used for insertion of a thermometer pocket. A bellow is recommended on the distillate outlet DN1.

Magnetically Operated

These reflux dividers are to be used with a electro-magnet and a timer. These have a swinging funnel mechanism which is operated magnetically from outside to remove the condensate or to return the reflux. Through this, correct control of reflux-ratio is possible. Funnel remains at 100% reflux position while magnet is inactive.

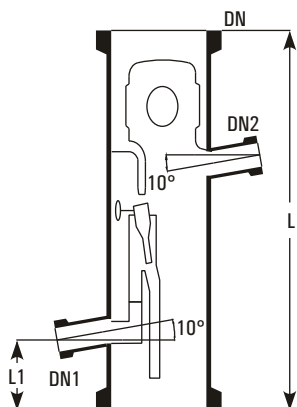

Cat.Ref.	DN	DN1	DN2	L	L1	Free Corss Section Cm2	Max. Product L/hr
RHM3	80	25	25	375	75	20	90
RHM4	100	25	25	400	75	50	180
RHM6	150	25	25	450	100	100	300
RHM9	225	25	25	550	100	150	500
RHM12	300	25	25	700	100	250	650
RHM16	400	40	40	800	150	350	1000

DN2 is used for insertion of a Thermometer Pocket. A liquid seal is recommended on the distillate outlet of this reflux divider to prevent the vapour passing directly to the receiver.

THERMOMETER POCKETS FOR REFLUX DIVIDER

These thermometer pockets are to be used with reflux dividers or column sections. DN refers to the nominal diameter of the Reflux divider or Column.

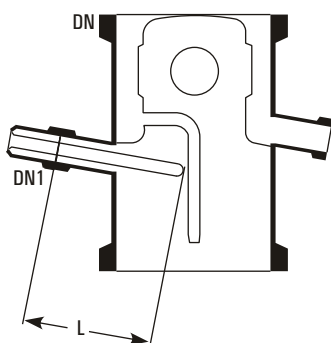

Cat.Ref.	DN	DN1	d	L
TP3	80	25	12	75
TP4	100	25	12	100
TP6	150	25	12	125
TP9	225	25	12	175
TP12	300	25	12	225
TP16	400	40	19	325
TP18	450	40	19	375

STANDARD UNITS



INTRODUCTION

Standard Units/ Assemblies are multi-purpose units having flexibility of utility. These units have been standardized by incorporating all basic & essential features such as heating, stirring, condensation, fractionation, cooling etc. for multi-purpose use. Therefore, though termed "Standard Units" from constructional view point they actually serve as "Flexi Units" from utility point of view.

These units find use in educational institutions, R&D centers and industries. They can be conveniently and quickly modified according to specific process needs due to modular construction. Borosilicate glass offers additional benefits of universal corrosion resistance, visibility and cleanliness.

1. Glass Reactor With Metal Jacket
2. Simple Distillation Unit
3. Reaction Unit
4. Fraction Distillation Unit
5. Reaction Distillation Unit
6. Multi Purpose Unit
7. Assembly over GLR

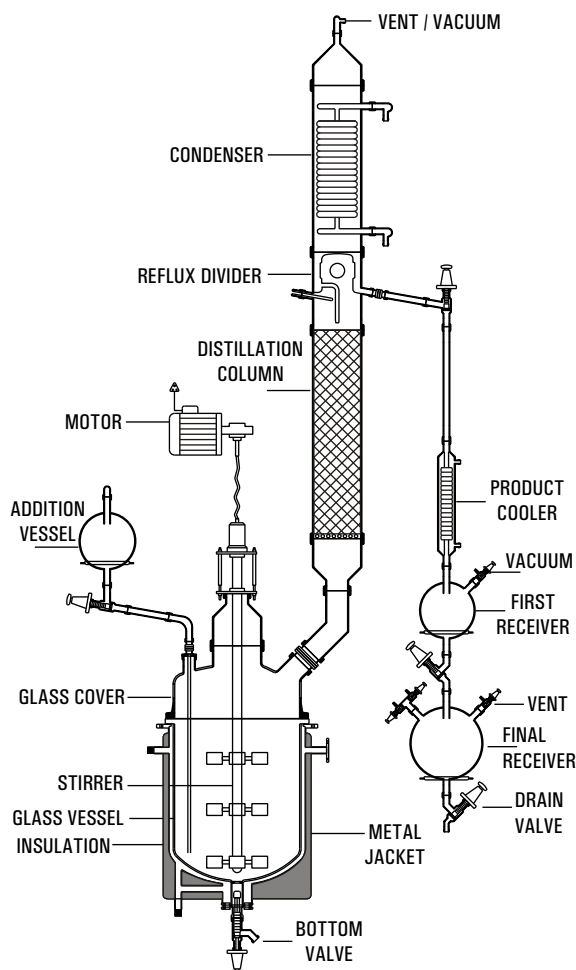

GLASS REACTOR WITH METAL JACKET

According to the customer's requirements and standard, we manufacture jacketed glass reactor which has many functions to satisfy kinds of experiments. Bhumi Scientific offers Glass Reactor with Metal Jacket for chemical & pharmaceutical industries for process development. Glass reactor will have metal jacket and metal insulation.

Glass / Glass Lined Reactor (GLR) : 5-500 liter

Pressure: - up to 1 Bar

Temperature: -50°C to +200°C

Material: Borosilicate glass 3.3 / PTFE/ SS 316.

Key Features:

- Reactor lift for easy opening i.e optimised for easy vessel cleaning
- Temperature monitoring and control
- Gas purging available
- Vacuum / exhaust piping arrangement
- Additional feeders / receivers as per requirement
- Solid feeding arrangement
- Ready for Cryogenic reactions (-50°C)
- Mixed systems with pressure reactor and vacuum distillation

SIMPLE DISTILLATION UNITS

It consists of a vessel mounted in a heating bath and fitted with a condenser for condensing the vapours. A receiver with drain valve can be added for receiving the condensate.

The units are available in vessel sizes of 20, 50, 100, 200 & 300 L and is suitable for operation under atmospheric pressure and full vacuum.

Unit Cat.Ref.	Reactor Capacity	Bath KW	Vapour Line	Condenser M ²
SDU20	20 L	4.5	80 DN	0.35
SDU50	50 L	6.0	100 DN	0.50
SDU100	100 L	9.0	150 DN	1.50
SDU200	200 L	12.0	150 DN	1.50
SDU300	300 L	16.0	225 DN	2.50

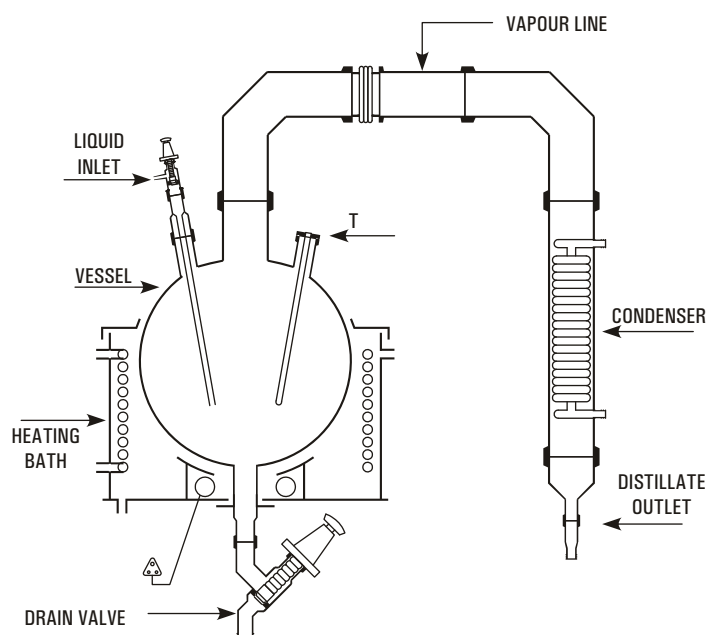

REACTION UNIT

This unit is used for carrying out reactions under stirred condition and with provision for simple reflux distillation.

The reaction vessel is mounted in a heating bath and fitted with addition vessel, motor-driven stirrer and provision for condensation with refluxing. The product is sub-cooled and collected in a receiver.

The units are available in vessel sizes of 20, 50, 100 & 200L and is suitable for operation under atmospheric pressure and full vacuum.

Unit Cat.Ref.	Reactor Capacity	Bath KW	Addition Vessel	Vapour Line	Condenser HTA M ²	Cooler HTA M ²	Receiver Size
RDU20	20 L	4.5	2 L	80 DN	0.35	0.10	5L
RDU50	50 L	6.0	5 L	100 DN	0.50	0.20	10L
RDU100	100 L	9.0	10 L	150 DN	1.50	0.35	20L
RDU200	200 L	12.0	20 L	150 DN	1.50	0.35	20L
RDU300	300 L	16.0	20 L	225 DN	2.50	0.50	20L

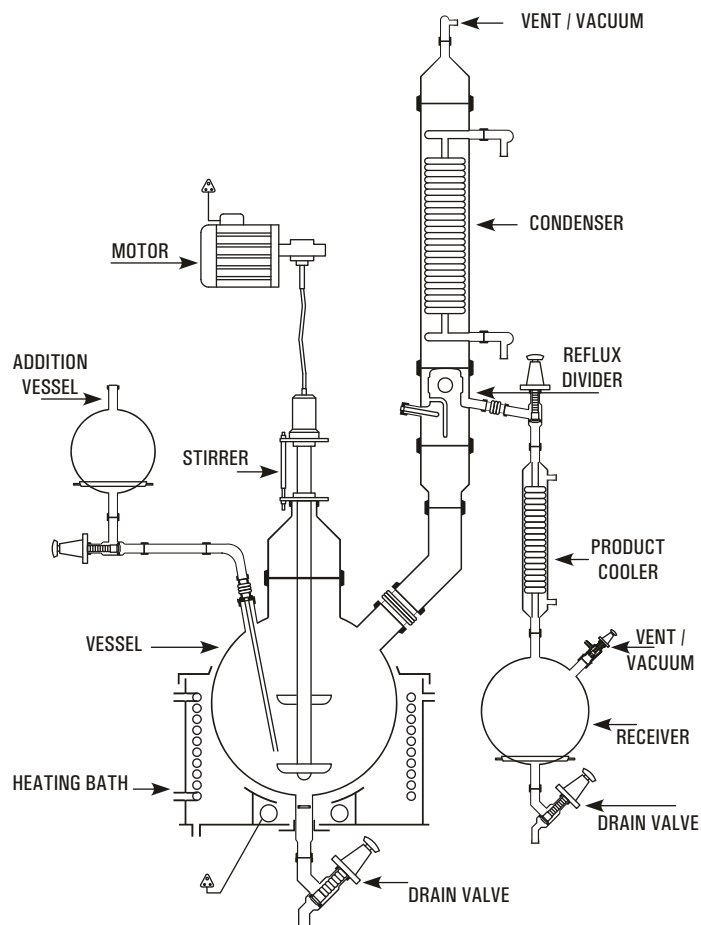

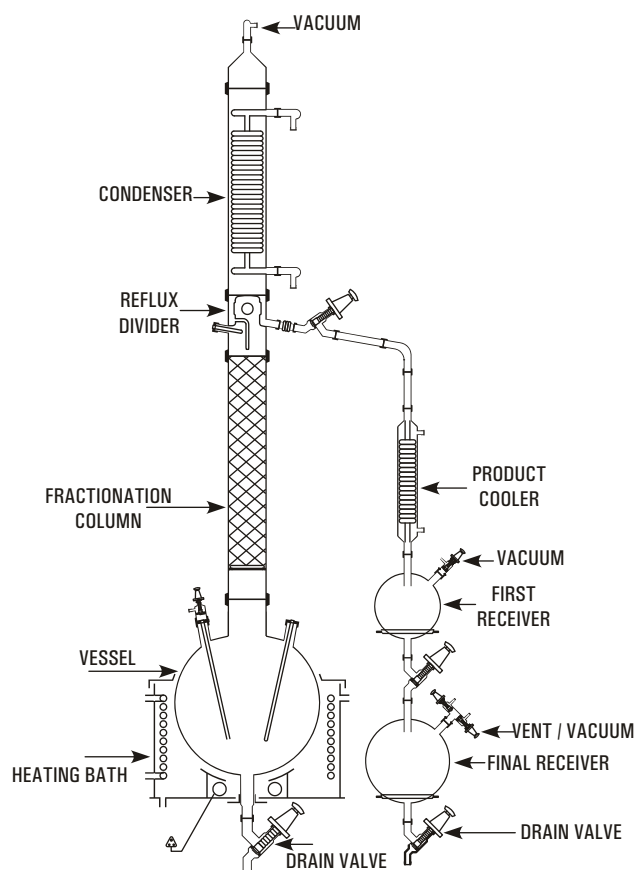

FRACTIONAL DISTILLATION UNIT

This is essentially a compact batch-type fractional distillation unit in which the reboiler consists of a vessel mounted in a heating bath and with a packed column above. The vapours from top is condensed and can be refluxed as per requirement.

The top product is sub-cooled and collected in receivers. The bottom product is finally drained from the reboiler through a drain valve.

The units are available in vessel sizes of 20, 50, 100 & 200L and is suitable for operation under atmospheric pressure and full vacuum

Unit Cat.Ref	Reactor Capacity	Bath KW	Addition Vessel	Vapour Line	Condenser HTA M ²	Cooler HTA M ²	Receiver Size
FDU20	20 L	4.5	2 L	80 DN	0.35	0.10	5L
FDU50	50 L	6.0	5 L	100 DN	0.50	0.20	10L
FDU100	100 L	9.0	10 L	150 DN	1.50	0.35	20L
FDU200	200 L	12.0	20 L	150 DN	1.50	0.35	20L
FDU300	300 L	16.0	20 L	225 DN	2.50	0.50	20L

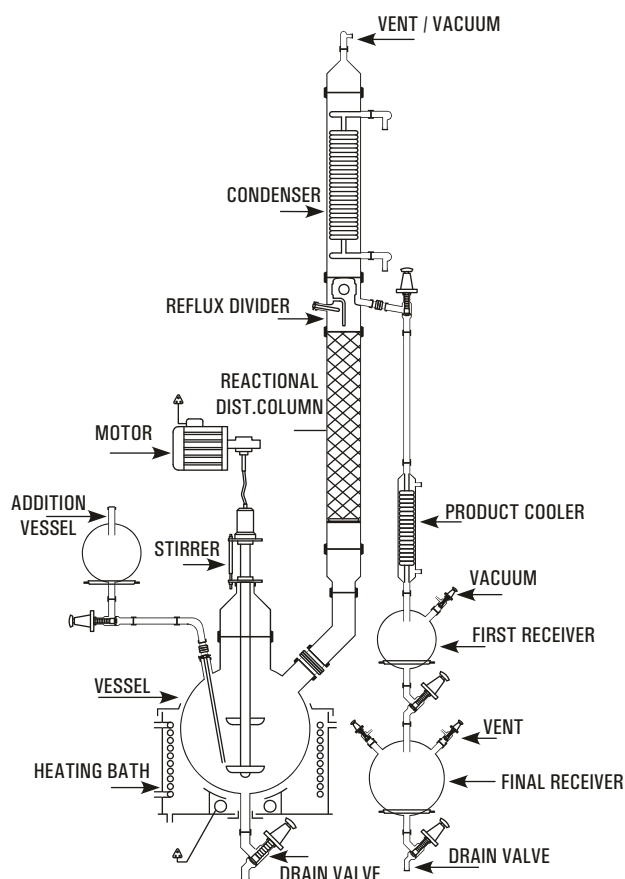

REACTION DISTILLATION UNIT

This is a versatile unit and can be used as Reaction Distillation Unit, Fractional Distillation Unit or a combination of both. All features of Reaction Distillation Unit and Fractional Distillation Unit are incorporated.

The units are available in vessel sizes of 20, 50, 100 & 200L and is suitable for operation under atmospheric pressure and full vacuum.

Unit Cat.Ref	Reactor Capacity	Bath KW	Addition Vessel	Vapour Line	Condenser HTA M ²	Cooler HTA M ²	Receiver Size
FRU20	20 L	4.5	2 L	80 DN	0.35	0.10	2L, 5L
FRU50	50 L	6.0	5 L	100 DN	0.50	0.20	5L, 10L
FRU100	100 L	9.0	10 L	150 DN	1.50	0.35	10L, 20L
FRU200	200 L	12.0	20 L	150 DN	1.50	0.35	10L, 20L
FRU300	300 L	16.0	20 L	225 DN	2.50	0.50	20L, 20L

MULTI PURPOSE UNIT

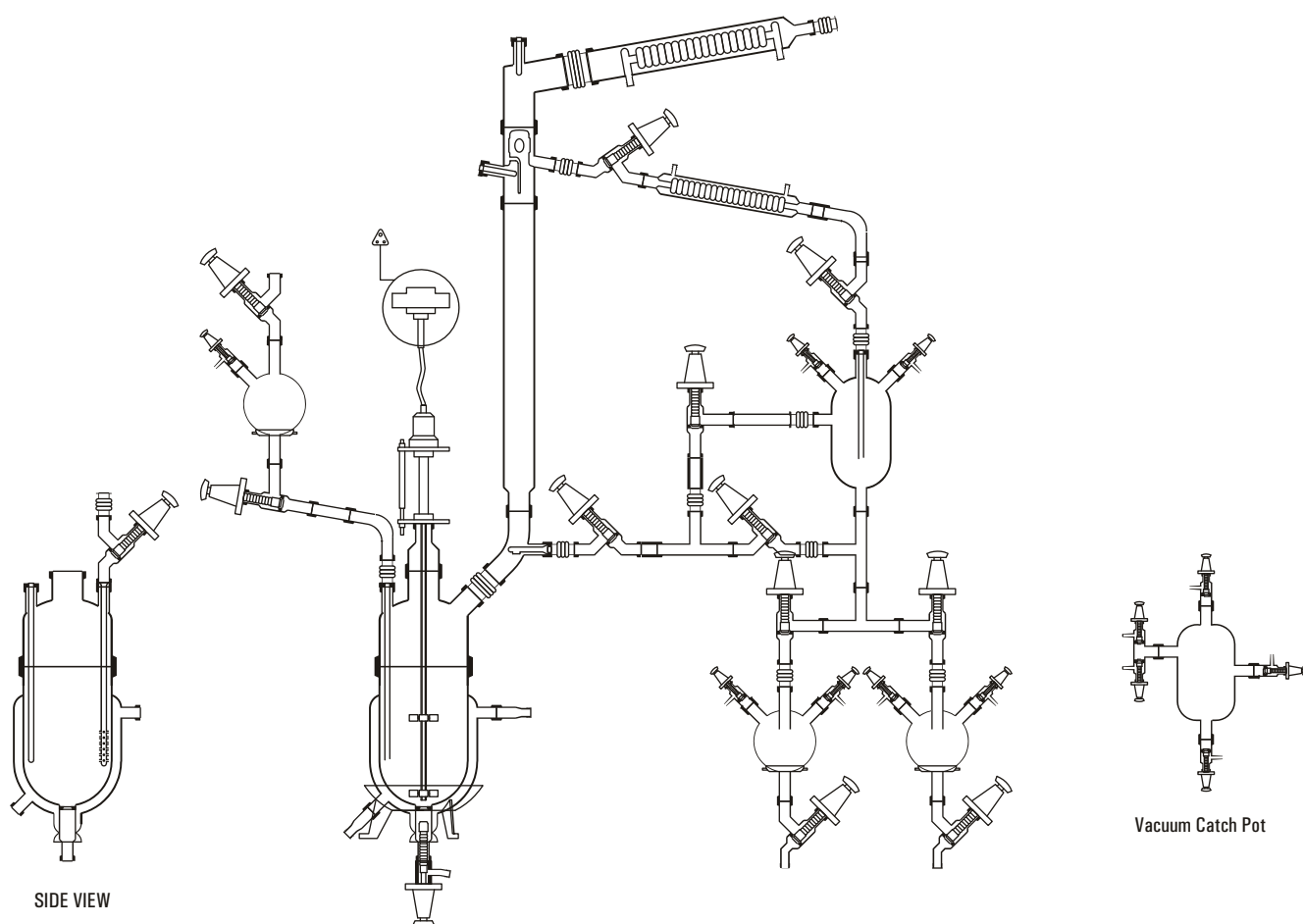

G Bhumi Offer multipurpose pilot plant for chemical and pharmaceutical industries for process development, scale-up, process simulation and kilo-scale cGMP production in batch and semi-batch operation. The pilot plant used for chemical processing includes solid charging, liquid charging, reaction, heating / cooling, rectification, auto / manual reflux arrangement, layer separation, product cooler, vacuum catch pot, vacuum header etc.

G The multipurpose pilot plant designed in such a way that we can modify the same easily as per process requirement.

Available with

- G Jacketed full glass reactor/ Cylindrical full glass reactor with Oil heating cooling bath / Spherical full glass reactor with Oil heating cooling bath
- G Multipurpose glass distillation overhead
- G Stainless steel / MS epoxy coated / MS painted frame supporting
- G Flame proof / Non flame proof / cGMP / non GMP models available
- G Excellent corrosion resistant.
- G Temp. Controller.
- G Gas purging, solid charging / multi liquid addition.
- G Vacuum / exhaust piping
- G Additional feeders / receivers
- G Solid feeding

Unit Cat. Ref.	Reaction Capacity	Bath KW	Addition Vessel	Vapour Line	Condenser HTA m2	Cooler HTA m2	Receiver Size
MPU 20	20 L	4.5	2 L	80 DN	0.35	0.10	2L, 5L
MPU 50	50 L	6.0	5 L	100 DN	0.50	0.20	5L, 10L
MPU 100	100 L	9.0	10 L	150 DN	1.50	0.35	10L, 20L
MPU 200	200 L	12.0	20 L	150 DN	1.50	0.35	10L, 20L
MPU 300	300 L	16.0	20 L	225 DN	2.50	0.50	20L, 20L

ASSEMBLIES OVER GLASS LINED REACTOR

Glass Lined Reactors are used instead of glass reactors specially when scale of operation is large and relatively high pressure steam is to be used as heating media. Quite often assemblies like Simple Distillation Unit, Reaction Distillation Unit, Fractional Distillation Unit etc. are installed above glass lined reactors. The basic features of these assemblies remain the same but glass shell and tube heat exchanger is preferred due to large scale of operation. A typical fractional distillation unit type assembly over GLR is shown in adjacent figure.

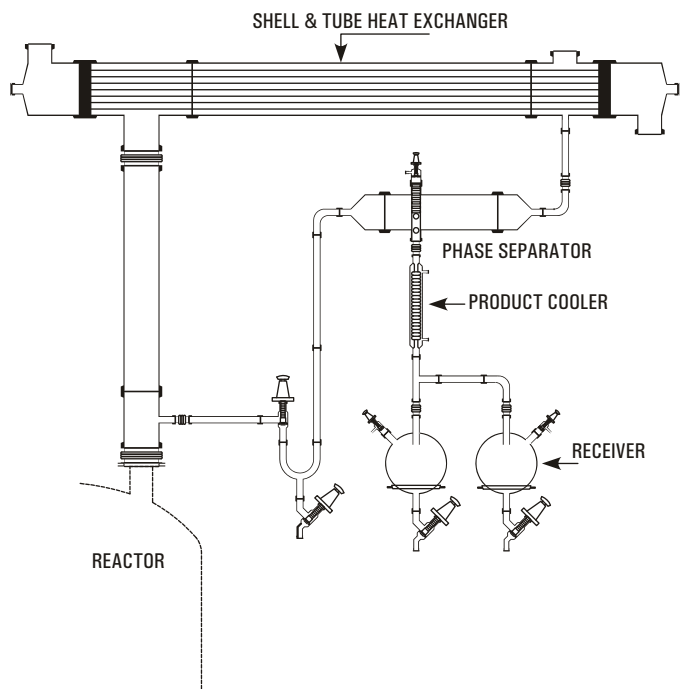

ROTARY FILM EVAPORATOR

2 TO 50 LITERS



INTRODUCTION

Rotary Film Evaporator is essentially a thin film evaporator. The rotating flask continuously covers a large surface area with a thin film which is ideal for rapid heat transfer. Fortuitously, the thin film also ensures uniform heat distribution without local heating. The facility to work the unit under full vacuum further facilitates evaporation at as low temperature as possible. That is to say, both boiling point and residence time are significantly reduced. These features combined, renders rotary film evaporator to be ideally

suited for evaporation of heat sensitive material. It is equally successful for evaporation of suspension in crystallization processes, drying of powder/ granules etc.

Rota Evaporator finds wide use from small scale laboratory set-ups to industrial operation. Bhumi Rotary Film Evaporator (GRFE) is preferred by both research and production facilities and has been used by laboratory and chemical, pharmaceutical and biotechnological industries.

2 TO 50 LITERS

SALIENT FEATURES

1. Universal corrosion resistance.
2. Auto controlled digital display of rotational speed and bath temperature.
3. Digital display of process time.
4. Automatic bath lifting.
5. Automatic bath lowering in case of power failure.
6. RS-232 Interface (Optional).
7. Withstands full vacuum.
8. Ideally suited for heat sensitive material.
9. Maintenance free working - Operational reliability.
10. Available in large sizes upto 400 Litre.

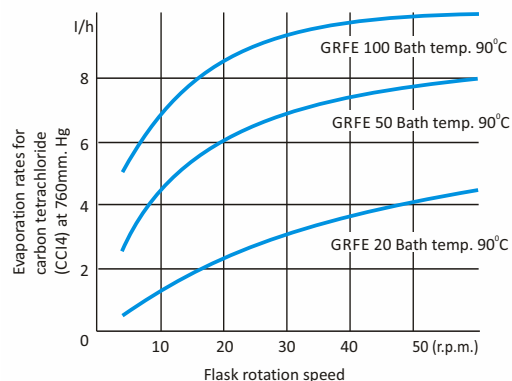

CONSTRUCTION

Bhumi Rotary Film Evaporators are completely self contained units consisting mainly of:

- G An electrically heated SS heating bath with facility for raising and lowering the height.
- G Rotating flask of corrosion resistant borosilicate glass which is connected to drive by a coupling.
- G The drive is a hollow glass shaft which also acts as vapour off-take pipe. The drive shaft is sealed on condenser/receiver with teflon seal. Power is transmitted to the shaft by a motor driven gear with provision for varying speed.
- G Condenser/receiver arrangements are of standard design depending on the model/size.

PERFORMANCE DATA

The performance of rota-evaporator depends on various parameters such as temperature differential between bath and contents of flask, RPM, flask capacity and working pressure. An indicative comparison of boil-up of CCl_4 rates for 20L, 50L and 100L is given in adjacent figure.

Technical informations related to various models are furnished below :

Model	Rotating Flask Cap. (Ltrs.)	Rotating Speed (rpm)	Electric Motor Rating	Condenser Cooling Area	Receiver Flask Cap. (Ltrs.)	Power Supply (Volt/Hz)	Bath Rating
GRFE 2	2	0-80	40 Watt	0.15	1	230 V, 50 Hz	2
GRFE 3	3	0-80	40 Watt	0.15	1	230 V, 50 Hz	2
GRFE 5	5	0-80	40 Watt	0.15	2	230 V, 50 Hz	2
GRFE 10	10	0-80	0.25 HP	0.20	5	230 V, 50 Hz	4
GRFE 20	20	0-80	0.25 HP	0.30	10	230 V, 50 Hz	4
GRFE 50	50	0-80	0.25 HP	0.50	20	230 V, 50 Hz	6

2 TO 50 LITERS

2, 3, 5 Ltrs.

Salient Features

- * Attractive Vertical Orientation for Industrial & Robust Use
- * 2 Ltr Pear Shaped evaporation flask, 1 Ltr receiver
- * Glass Coil Condensor with 0.10 sq. mtr HTA
- * Digital RPM indicator & VFD based speed control, 0.25 Hp Motor, 0-80 RPM
- * Digital Temperature Indicator & controller
- * Digital vapor temperature indicator
- * Manual UP & Down of Bath
- * Jacketed Bath with electrical heaters, 2 KW with Overflow nozzle & drain valves
- * Durable gearbox, with Motor Encased into the Mechanical Assembly
- * Fully PU Coated
- * The whole unit is base mounted.
- * Fully tested & ready to use !!

Optional

- * Chiller Unit
- * Vacuum Pump with Setup

10, 20, 50 Ltrs.

Salient Features :

- * Attractive Vertical Orientation
- * Digital RPM indicator & VFD based speed control
- * Digital Temperature Indicator & Controller
- * Digital Process Time Indication
- * Digital vapor temperature indicator
- * Motorized VFD based UP & down of bath
- * S.S. bath with Jacket & electrical heaters with overflow nozzle & drain valves
- * Durable S.S. gearbox, with motor encased into the Mechanical Assembly
- * Complete glass assembly as per the specs in the table
- * Anti splashing hood
- * PU coated
- * The whole unit is mounted on lockable wheels.
- * Dimensions : 1100 x 600 x 1500 approx (with glass assembly)
- * Fully tested & ready to use !!

Optional :

- * UPS back up for auto lowering bath
- * Chiller unit
- * Vacuum pump with setup

TECHNICAL PACKAGES

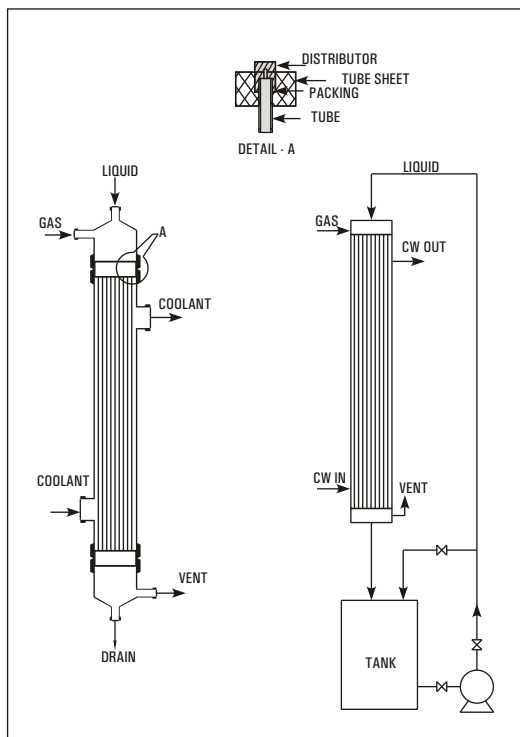

Falling Film Absorber

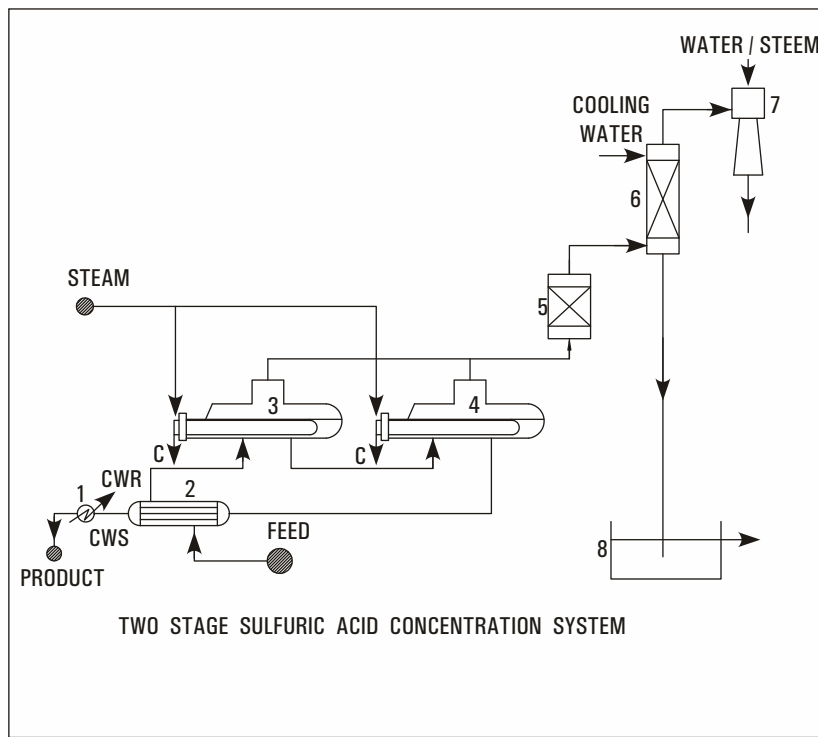

Sulphuric Acid Concentration System

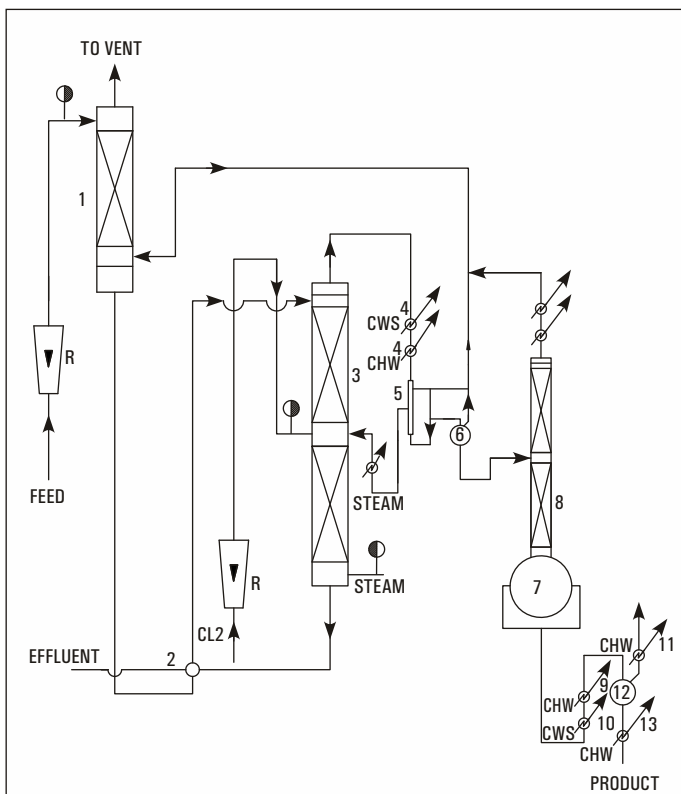

Bromine Recovery Systems

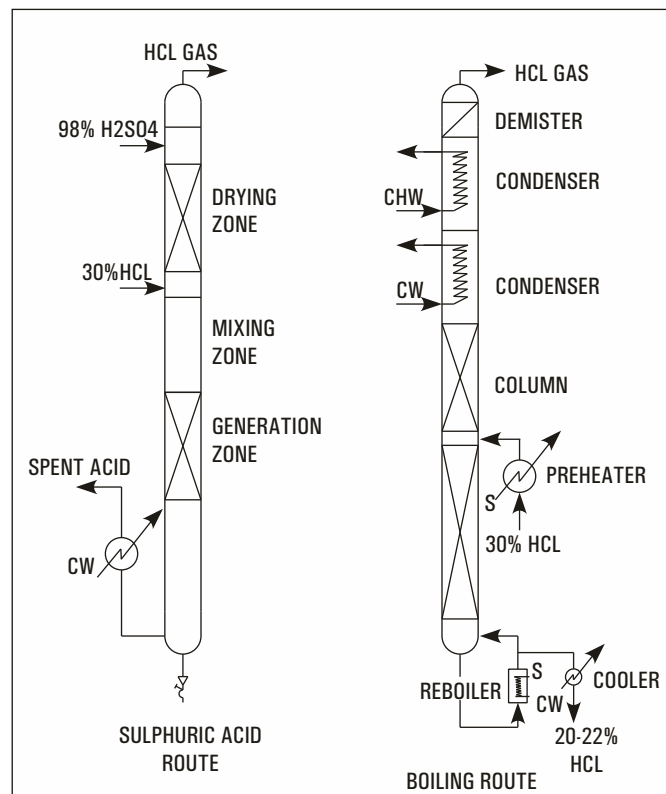

Anhydrous Hcl Gas Generator

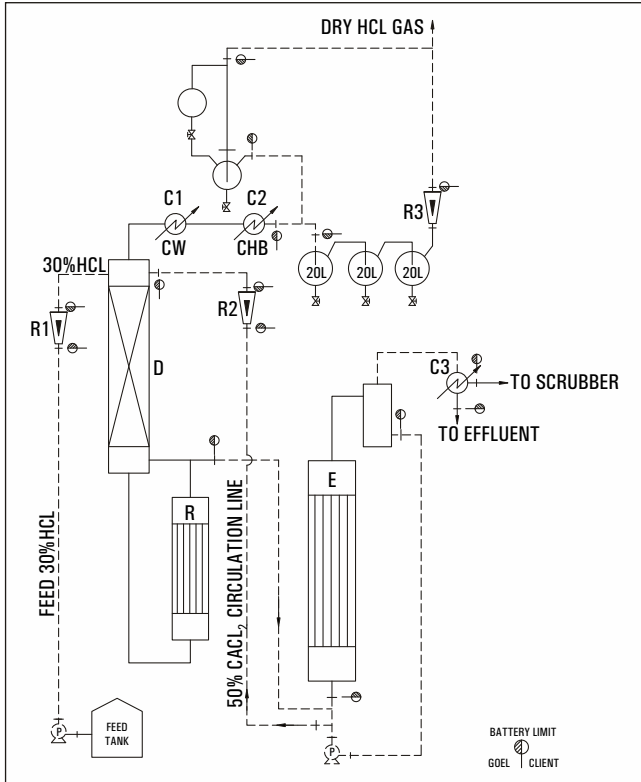

Anhydrous HCL Gas Generator - Calcium Chloride Route

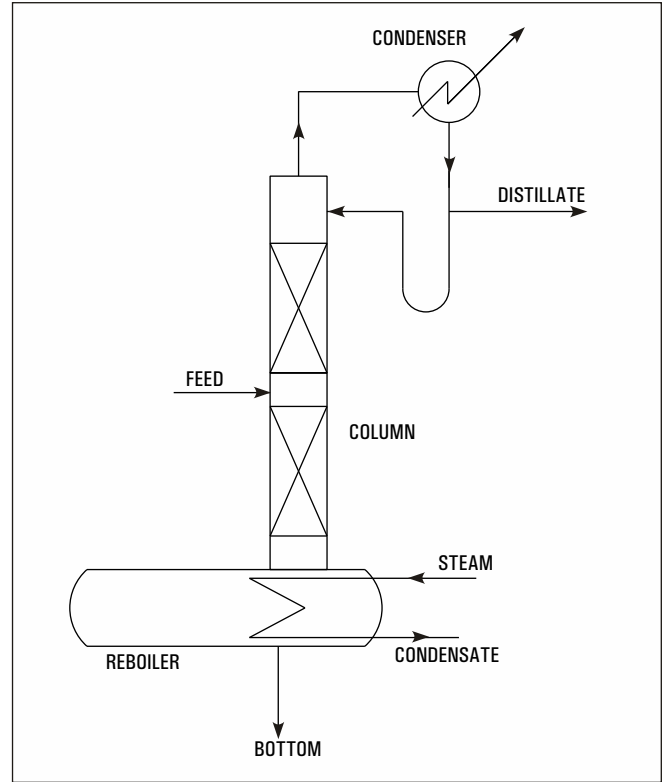

Continuous Distillation System

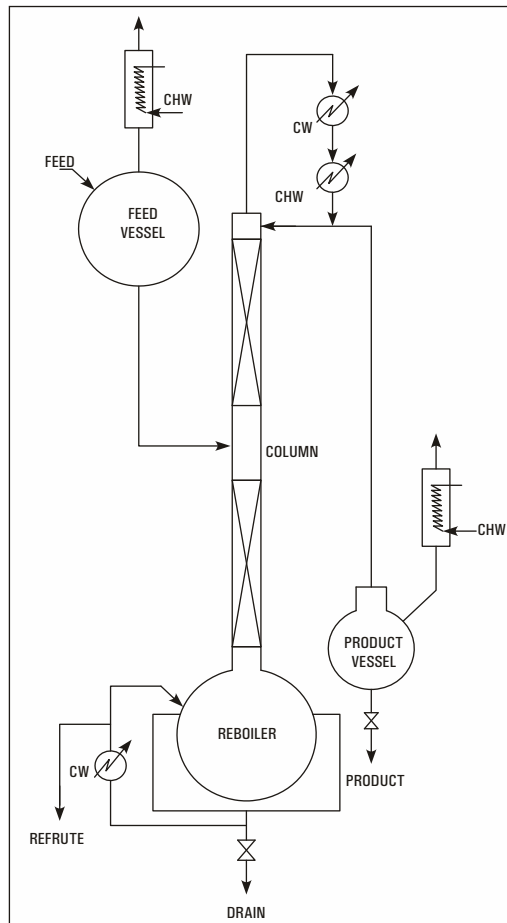

Solvent Recovery